Research program
heat pumping technologies, cogeneration, refrigeration

Seasonal performance calculation for residential heat pumps with combined space heating and hot water production (FHBB Method)

Worked out by
C. Wemhöner **FHBB**
Prof. Dr. Th. Afjei **FHBB**
University of Applied Sciences Basel
Institute of Energy
Fichtenhagstrasse 4, CH-4132 Muttenz
c.wemhoener@fhbb.ch, t.afjei@fhbb.ch

in charge of
Swiss Federal Office of Energy

Summary

The domestic hot water production in modern buildings is a growing part of the total heat energy demand. Thus the combined hot water production is gaining interest. For the assessment of the efficiency of the combined hot water production, the overall seasonal performance (SPF) is important. A hand calculation method, which can calculate the seasonal performance factor with adequate exactness is thereby an important tool for the estimation of the capability of the system configuration. Therefore two research projects in charge of the Swiss Federal Office of Energy were started, which are a national contribution to the Annex 28 of the Heat Pump Programme of the International Energy Agency IEA.

In the present European and national standardisation different calculation methods to evaluate the seasonal performance of heating and domestic hot water systems including heat pumps exist, that provide calculation methods of heating heat pumps, heat pump water heaters and partly the alternate operation of heat pumps for heating and domestic hot water production. However, the existing calculation methods are limited with respect to system configuration and boundary conditions. Methods for the simultaneous operation do not exist. Only in American standardisation ASHRAE standard 137 deals with the simultaneous hot water production with desuperheater in the application field of air-to-air heat pumps.

However the existing methods are a good basis for the extension of the methodology to simultaneous operation. All detailed hand calculation methods use the so called "bin approach", which is based on the annual frequency of the ambient dry bulb air temperature, which is distributed into fixed classes of the ambient temperature. Different operation modes (e.g. for heating and domestic hot water operation) are combined to an overall seasonal performance factor by an energetic weighting with the respective energetic fractions of the used energy. As simultaneous operation implies a significant change in the heat pump characteristic, an adequate test procedure had to be developed first in the parallel project "Test procedure for heat pump with combined space heating and domestic hot water production" at the Swiss national test centre WPZ Töss. The resulting heat pump characteristics were used in the presented calculation method of this project.

In this project two systems for simultaneous operation were in focus: one system with alternate domestic hot water production by switching from the heating to the domestic hot water operation in the case of hot water demand. The other system works with a cascade ("Swiss Retrofit Heat Pump"), where the lower stage is used for the heating operation and the upper stage for the domestic hot water. In simultaneous operation, the upper stage uses the condensate subcooling of the lower stage for the hot water production.

The calculation method covers monovalent and monoenergetic heat pump heating systems for the combined space heating and domestic hot water production. A comparison of the calculation method with simulations showed a deviation to about 6% lower SPF values. However results have to be validated in detail. Difficult is still the prediction, which part of the energy demand is produced in combined operation. This part depends on the one hand on the output capacity characteristic of the heat pump, but is influenced on the other hand by the used control system and the tapping profile. Thus a factor for simultaneous operation is defined. Preliminary simulations based on the measured heat pump characteristic had the result, that depending on the boundary conditions, the maximum simultaneous operation is in the range of 60%.

This report was worked out in charge of the Swiss Federal Office of Energy. For the contents and conclusion only the authors are responsible.

Zusammenfassung

Die Warmwasserbereitung nimmt in modernen Gebäuden einen immer grösseren Anteil am Gesamtwärmebedarf ein. Daher gewinnt eine mit der Raumheizung kombinierte Warmwasseraufbereitung zunehmend an Bedeutung. Zur Beurteilung der Effizienz der kombinierten Warmwasseraufbereitung ist ein hoher Gesamtnutzungsgrad ausschlaggebend. Ein Handrechenverfahren, das in der Lage ist, den Jahresnutzungsgrad verschiedener Systeme mit ausreichender Genauigkeit zu berechnen, ist daher ein wichtiges Hilfsmittel zur Beurteilung von verschiedenen Systemkonfigurationen. Daher wurden im Auftrag des Bundesamtes für Energie zwei Forschungsprojekte zu diesem Thema lanciert, welche den nationalen Beitrag zum Annex 28 im Wärmepumpenprogramm der Internationalen Energieagentur IEA bilden. In der derzeitigen europäischen und nationalen Normung existieren einige Handrechenverfahren für die Jahresarbeitszahlen von Heizungs- und Warmwassersystemen mit Wärmepumpen. Sie eignen sich für die Berechnung von Wärmepumpen für den Heizbetrieb, Wärmepumpenwassererwärmern und teilweise auch den alternativen Betrieb der Heizung und Warmwasserbereitung mit der gleichen Wärmepumpe. Die bestehenden Verfahren weisen allerdings unterschiedliche Einschränkungen bezüglich der Systemkonfiguration und Randbedingungen auf. Verfahren für den simultanen Betrieb existieren noch nicht. Einzig im Bereich der amerikanischen Normung behandelt der ASHRAE Standard 137 die simultane Warmwassererwärmung mittels Enthitzer für den Anwendungsbereich von Luft-/Luft-Wärmepumpen.

Die existierenden Verfahren bilden jedoch eine gute Grundlage für eine Erweiterung der Rechenmethodik auf den simultanen Betrieb. Sämtliche detaillierte Handrechenverfahren setzen das sogenannte Bin-Verfahren ein, dem eine Häufigkeitsverteilung der Aussentemperatur auf fixe Temperaturintervalle („bins“) zugrunde liegt. Verschiedene Betriebszustände (z.B. für Heiz- oder Warmwasserbetrieb) werden in einer Gesamt-Jahresarbeitszahl zusammengefasst, indem die einzelnen Jahresarbeitszahlen entsprechend der produzierten Energieanteile gewichtet werden. Da sich die Wärmepumpencharakteristik im simultanen Betrieb aber erheblich ändert, musste im Parallelprojekt „Wärmepumpentest für die kombinierte Raumheizung und Warmwasseraufbereitung“ zuerst ein geeignetes Prüfverfahren entwickelt werden. Die daraus entstandenen Kennfelder gingen in die hier vorgestellte Berechnungsmethode ein.

Im vorliegenden Projekt wurden zwei unterschiedliche, kombiniert arbeitende Systeme untersucht: Das erste System erzeugt Warmwasser im Alternativbetrieb, indem die Wärmepumpe bei Warmwasserbedarf von der Heizung auf einen Beistellboiler zur Warmwasserbereitung umgeschaltet wird. Das zweite System arbeitet mit einer speziellen Kaskadenschaltung („Swiss Retrofit Heat Pump“), bei der die untere Stufe für den Heizbetrieb und die obere für den Warmwasserbetrieb genutzt wird. Im Simultanbetrieb nutzt die obere Stufe die Kondensatunterkühlung der unteren Stufe für die Warmwasseraufbereitung. Die Berechnungsmethode eignet sich für monovalente, monoenergetische und bivalente Wärmepumpenheizsysteme zur kombinierten Raumheizung und Warmwassererzeugung. Ein Vergleich der Rechenmethode mit Simulationen ergab für die Berechnung 6% tiefere Jahresnutzungsgradwerte. Die Resultate müssen jedoch noch genauer validiert werden. Schwierigkeiten bereitet noch die Vorhersage, welcher Anteil der Wärme im simultanen Betrieb erzeugt wird. Dieser Anteil hängt auf der einen Seite von der Leistungscharakteristik der Wärmepumpe ab, wird auf der anderen Seite aber auch von der eingesetzten Regelung und dem Warmwasserbezugsprofil beeinflusst. Es wurde daher ein Gleichzeitigkeitsfaktor als Eingabegrösse definiert. Erste Simulationen auf Grundlage der gemessenen Wärmepumpenkennfelder ergaben, dass unter den zugrundegelegten Randbedingungen die maximal mögliche Wärmepumpenlaufzeit im Simultanbetrieb im Bereich von 60% liegt.

Diese Arbeit ist im Auftrag des Bundesamtes für Energie entstanden. Für den Inhalt und die Schlussfolgerungen sind ausschliesslich die Autoren dieses Berichts verantwortlich

Contents

SUMMARY	III
ZUSAMMENFASSUNG	IV
CONTENTS	V
1 OBJECTIVES	1
2 STATE OF THE ART IN INTERNATIONAL STANDARDISATION	3
2.1 CALCULATION METHODS FOR THE SEASONAL PERFORMANCE FACTOR.....	3
2.1.1 <i>Description of calculation methods from standards</i>	4
2.2 METHODS OF THE THIRD CATEGORY	6
2.2.1 <i>VDI 2067-6 detailed version</i>	6
2.2.2 <i>HTA Lucerne detailed version</i>	8
2.2.3 <i>CEN/TC 228/WG 4</i>	9
2.2.4 <i>ASHRAE 116 in connection with ASHRAE 137</i>	10
2.2.5 <i>DIN 4702, part 8</i>	13
2.3 COMPARISON OF THE FOUND METHODS	14
2.4 CONCLUSION OF THE SURVEY	16
2.4.1 <i>Scope of the method in international standardisation</i>	16
2.4.2 <i>Bin method</i>	16
2.4.3 <i>Energy approach vs. power balance</i>	16
3 PRINCIPLES OF THE FHBB-METHOD	19
3.1 SYSTEM BOUNDARIES	19
3.2 INPUT DATA FOR THE CALCULATION OF THE SPF	21
3.3 CALCULATION PROCEDURE OF THE FHBB-METHOD.....	22
3.3.1 <i>Introduction to the bin method</i>	22
3.4 CALCULATION METHOD STEP BY STEP.....	24
3.4.1 <i>Preprocessing of the meteorological data</i>	24
3.4.2 <i>A - Heating mode</i>	24
3.4.3 <i>B - Hot water mode</i>	35
3.4.4 <i>AB - Alternate operation mode</i>	40
3.4.5 <i>C - Simultaneous operation mode</i>	40
4 DATA SOURCES FOR THE SINGLE CALCULATION STEPS	47
4.1 METEOROLOGICAL DATA.....	47
4.1.1 <i>Preprocessing of the meteorological data</i>	47
4.2 SOURCE TEMPERATURE	50
4.2.1 <i>Air-to-water heat pumps</i>	50
4.2.2 <i>Brine-to-water heat pumps</i>	50
4.2.3 <i>Water to water heat pumps</i>	52
4.3 HEATING AND HOT WATER DEMAND.....	52
4.3.1 <i>Energy requirement of the heating system</i>	52
4.3.2 <i>Energy requirement of the domestic hot water system</i>	53
4.4 VALUES FOR COP AND OUTPUT CAPACITY	55
4.4.1 <i>Test procedures in European standardisation</i>	55
4.4.2 <i>Methods for temperature correction of standard COP and output capacity</i> ... 59	
4.5 LOSSES OF THE HEAT PUMP DUE TO CYCLIC OPERATION.....	63
4.5.1 <i>Dynamic heat pump test</i>	63
4.5.2 <i>ASHRAE 116 in combination with ARI 210/240</i>	67
4.5.3 <i>Technical specification of CEN/TC 113/WG 7 N 366</i>	68

4.5.4	<i>Measurements of Jacques Bernier</i>	68
4.5.5	<i>Approach for calculation of cyclic losses</i>	68
4.6	TEST PROCEDURE FOR SIMULTANEOUS OPERATION	69
4.6.1	<i>Developed test procedure for simultaneous operation</i>	69
4.7	FACTOR OF SIMULTANEOUS OPERATION.....	71
4.7.1	<i>Theoretical considerations</i>	72
4.7.2	<i>Results from simulations</i>	72
4.8	COMPARISON OF THE CALCULATION METHOD WITH SIMULATIONS	74
5	CALCULATIONS FOR THE TWO MEASURED SYSTEMS	77
5.1	SYSTEM DESCRIPTION.....	77
5.1.1	<i>Alternate operating system</i>	77
5.1.2	<i>Simultaneous operating system</i>	78
5.2	DISCUSSION OF THE MEASUREMENTS OF THE TWO SYSTEMS	80
5.3	SEASONAL PERFORMANCE CALCULATION FOR THE TWO SYSTEMS	84
5.3.1	<i>System configuration</i>	84
5.3.2	<i>Boundary conditions</i>	84
5.3.3	<i>Assumptions</i>	86
5.3.4	<i>Generator seasonal performance factor of the two systems</i>	87
5.3.5	<i>System seasonal performance factor according to RAVEL definition</i>	90
5.3.6	<i>Overall system seasonal performance factor</i>	95
5.3.7	<i>Summary</i>	97
6	CONCLUSIONS	99
7	ACKNOWLEDGEMENTS	101
8	NOMENCLATURE	103
9	REFERENCES	109
10	APPENDIX	113

1 OBJECTIVES

The ratio of the heat demand for the hot water production is increasing with the improvement of the insulation of modern buildings. Thus concepts for the alternate or simultaneous production of space heating and domestic hot water are gaining interest and are introduced into commercial systems. Important for these systems is a high overall seasonal efficiency. However, there are neither comprehensive test procedures nor calculation methods for the simultaneous hot water production available in the international standardisation.

Seasonal performance factors are used for comparison of different energy systems, as an input for a further calculation, e.g. an economic calculation of costs or a calculation of emission of pollutants, or as a quality benchmark expressed in a quality or energy label. Moreover funding and subsidies for energy systems are often based on certain performance characteristics. Last but not least, seasonal performance is used for a certain quality and warranty of the installing companies.

Therefore the objective of the project is the development of a transparent and easy-to-use hand calculation method for the seasonal performance factor of heat pump systems on the basis of existing standard calculation methods and publicly available data. The method is to be applicable for users without special knowledge, e.g. in the field of computer simulations. The scope of the method are systems for only heating and only domestic hot water operation as well as both alternate and simultaneous operating systems for combined space heating and hot water production. Focus for the combined production of heating and hot water energy are two systems, which are available on the Swiss market: For alternate domestic hot water production, a system configuration with parallel hot water storage and hot water priority, for simultaneous operation a heat pump concept, which uses condensate subcooling in the simultaneous operation mode, are to be investigated. As a first step, the calculation method is restricted to hydronic distribution and monoenergetic operation. Heat sources to be considered are ambient air, water and the ground in combination with brine to water heat pumps. The method aims to assess the potential of efficiency gains and thereby energy savings of simultaneous domestic hot water production with the same heat pump unit.

To facilitate the application of the method, an easy-to-use hand calculation method guided by tables and a more comprehensive version implemented in an Excel-sheet are under development on the basis of the here presented FHBB-method. As the method requires input data of the component characteristics like output capacity, heat losses and COP of integrated system components, which are taken from standard testing of the components, a parallel project at the Swiss national heat pump test center WPZ at Winterthur-Töss [7] has worked out a test procedure which can deliver the required data for the calculation method. The two projects are carried out in close co-operation.

The method shall be the basis of an international standard. Therefore cooperation with the standardisation committee SIA 384 on the national level by participation in the TC 228/WG 4 of the European Standardisation Committee CEN, which is developing calculation methods for heating systems, is in progress.

Moreover the project is the first Swiss contribution to Annex 28 of the Heat Pump Programme of the International Energy Agency called "Test procedure and seasonal performance calculation of residential heat pumps with combined space heating and domestic hot water production" [31]. The IEA HPP Annex 28 was initiated by Switzerland and meanwhile 10 countries are participating in the Annex. Objective of the Annex 28 are more comprehensive test procedures and calculation methods for different system configurations for the combined space heating and hot water production, where promising refrigerants as e.g. CO₂ in a transcritical cycle are considered, as well. The Annex 28 is coordinated by Switzerland.

2 STATE OF THE ART IN INTERNATIONAL STANDARDISATION

2.1 Calculation methods for the seasonal performance factor

Seasonal performance calculation is done to assess the time-dependent performance of energy systems under changing operation conditions over a certain time span, usually a year. Input data to calculation methods are normally steady-state values, which are valid for a specific operation condition or a certain range of operation conditions. By cumulating the operation conditions over the year the efficiency can be estimated. An addition of these instantaneous values over the whole time span thus delivers the performance. An exact formulation of the seasonal performance factor is given in eq. 1

$$\text{SPF} = \frac{\int_{t=0}^{t_{\text{end}}} \phi_{\text{used}} dt}{\int_{t=0}^{t_{\text{end}}} P_{\text{in}} dt}$$

eq. 1

where ϕ_{used} stands for all forms of useful energy as output of the system and P_{in} represents the sum of all power input required to produce the useful energy. dt is the time step.

This formulation of the SPF is only suited for computational methods, because many time steps have to be calculated.

Hence, dependent on application, methods with a different degree of sophistication were developed and are partly introduced in standards to give guidelines for the expected seasonal performance.

In the field of heat pumps the following methods can be found to estimate or to calculate the seasonal performance:

Approximative estimation methods:

There are two kinds of methods to estimate the seasonal performance:

- the first kind uses empirical values from field measurements of the performance of installed systems. The systems are characterised by their configuration, for heat pumps for instance by their driving device (electrically driven or combustion engine driven heat pumps), the heat source (air-to-water or brine-to-water) and the size of the system. Short-cut calculation methods of this kind can be found in standards, e.g. in [1].
- the second kind takes mean values over the year assuming an average performance of the heat pump. The time-dependent differences are aggregated to one point of time in the middle of the operation range. It is postulated, that the differences around this operation points are balanced. Typically operation points of heat pumps in the middle of standard testing points are used, e.g. A2/W35. A method using an empirical exergetic efficiency factor of 0.4 and the standard testing point of A2/W35 is described in [38].

Hand calculation method with correction factors:

A second category of calculation methods uses empirical factors for the correction of standard testing points with the operation conditions. These methods are often introduced as short-cut calculation method in standards, which comprise a more detailed version, as well. The found methods of this kind are described in more detail below.

A more sophisticated approach is the bin method, which is described in detail in chapter 3. The principle of the method is a division of the time period into classes. For these classes, called bins, the operation conditions are evaluated and summed up to receive the SPF for the whole period.

Computational calculation methods of the seasonal performance

As the step to computer calculations is made, it has to be differentiated between (a) steady state calculation method considering a quasi stationary energy state on the basis of hourly values, and (b) dynamic calculation methods.

(a) Steady state calculation methods use stationary states of the system hence in every calculation step the system is considered to be in balance and shows no transient effects.

(b) Dynamic calculation programs consider transient effects, as well. The calculation steps can be very short and calculation can become expensive associated with an enhanced exactness of the solution. With regard to standards, dynamic simulation is not so common, as hand calculation methods are required. However, a development to use simulation programs for the evaluation of test results by the method of parameter identification is increasing, starting with the DST method (dynamic system testing) according to EN 12976-2 [33], certain other methods, like the Component Testing System Simulation (CTSS method according to ENV 12977-2 [34]) were developed to reduce testing expenses. In connection with these methods, often annual simulations with the identified parameters are done to evaluate the seasonal performance, as well.

2.1.1 Description of calculation methods from standards

As basis for the development of the calculation method a survey of existing directives and standards or otherwise documented methods has been carried out to characterise the state of the art in international standardisation.

On the European level of CEN-standardisation actually no test procedures or calculation methods are available for combined operation.

In Sweden standards for the testing of combined working exhaust-air heat pumps are available [45], [46] which are referenced in the Nordtest method NT VVS 086 [44].

The accessible calculation methods found in the survey can be classified in three groups:

1. methods, that directly give an SPF (seasonal performance factor) dependent on the operation conditions and/or system configuration, e.g. in [1]
2. methods, that evaluate data of the rated COP (coefficient of performance) and apply correction factors with regard to the operation conditions, e.g. in [2]
3. methods, that evaluate the annual frequency of the ambient temperature as basis to weight corrected COP values at various operation points

A method of the first category is the

- VDI 2067 part 6 [1], short cut method

where seasonal performance factors from measurements and experience are given dependent on the heat source, the type of heat pump (electrically/combustion engine driven) and the supply/return temperature combination.

Methods of the second category are the

- VDI 4650 part 1 [2]
"Calculation of heat pumps: Short cut method for the calculation of the annual expenditure factor of heat pumps: Electric heat pumps for room heating"

Part 1 treats heat pumps for single heating operation. Part 2, which deals with domestic hot water systems, is in preparation. However, a similar calculation method is implemented and released already in the ENEC 2002, the German energy directive, which is based on a series of single standards, the most important of them the DIN V 4701-10 [35] for the calculation of the system technology and the DIN V 4108-6 [36] for the calculation of the building.

The SPF of the heat pump is calculated based on one standard testing point for brine-to-water and water-to-water heat pumps and three testing points for air-to-water heat pumps. Tabulated correction factors are applied for correction of standard testing points:

In the case of liquid-to-water heat pumps

- one for the deviation of condenser temperature during measurement and operation
- one for the source and sink temperature operation conditions and
- one for auxiliary energies of the source pump

In the case of air-to-water heat pumps

- one for the deviation of condenser temperature during measurement and operation
- one for each testing point for the geographical site of the heat pump (limited to Germany)
- HTA Lucerne [4] Short cut method
The short cut method of the HTA Lucerne considers air-to-water and brine-to-water heat pumps for monovalent single or alternate operation. For air-to-water systems, three standard testing point are taken into account. Correction factors are given for operation temperatures and meteorological conditions of the site, for hot water operation correction factors for distribution and storage losses are applied, if not already included in the COP values. The single SPF values for heating and domestic hot water are combined to an overall SPF by the energetic fraction for heating and hot water respectively. For brine-to-water, one testing point is used and brine temperature is considered constant. Correction factors are derived from the detailed version of the method, which is described below.

As a method with transparent correction factors is meant to be developed in this project, methods of the third category are in focus.

The survey has shown the following methods to be relevant for the development:

- VDI 2067-6 [1] (detailed version)
"Economy calculation of heat consuming installations: Heat pumps"
- Hand calculation method HTA Lucerne (detailed version) [4]
"Hand calculation method to determine the yearly performance factor of heat-pump heating systems for room heating and domestic hot water preparation"

- CEN/TC 228/WG 4 N 259 [5]
"Methods for calculation of system energy requirement and system efficiency – heat pumps"
- ASHRAE standard 116 [6]/ASHRAE standard 137 [47]
"Methods of testing for rating seasonal efficiency of unitary air conditioners and heat pumps" / "Methods for testing for Efficiency of Space-Conditioning/Water Heater Appliances that include a Desuperheater Water Heater"
- Calculation based on DIN 4708-2, part 8 [23]
"central heating boilers: determination of the standard efficiency and the standard emissivity", adaption of performance calculation method for boilers to heat pump documented in [22]

2.2 Methods of the third category

The found methods of the third category are characterized in this paragraph with respect to the criteria

- Consideration of meteorological data
- Definition of operation points
- System specification
- Integration of domestic hot water calculation
- Evaluation of the source and sink temperature
- Calculation of the heat demand from the annual frequency of ambient air temperature
- Evaluation of COP values
- Adaptation of output capacity and COP to the operation conditions
- Back-up system

An overview of the characterization can be found in the Tab. 3 at the end of the paragraph.

Further on an analysis of the found calculation methods with regard to the objectives of this project is carried out.

2.2.1 VDI 2067-6 detailed version

Scope:

The VDI 2067 is a guideline for the economic calculation of the heating systems from the year 1989. Part 6 refers to heat pump systems. To evaluate the costs of a heat pump system, a seasonal performance calculation is integrated in the guideline. Scope of the method are electrically driven as well as combustion engine driven heat pump systems with single compressor. Heat sources are surface water, ground water, ambient air and horizontal ground collectors. U-tube vertical borehole heat exchangers could be treated as well, but no default input data is given for the source temperature. The detailed method uses a temperature bin approach, which is described in detail in chapter 3.

Input data:

- annual frequency of the ambient dry bulb air temperature
- design outdoor temperature
- design indoor temperature
- operating temperatures of the heating system
- COP-values of the heat pump over the whole operation range
- Source temperature of the heat pump

Methodology:

The number of operation points and thereby the number of bins is free to choose. Recommendation for the resolution is four bins. For each bin, the amount of energy is represented by F_i , which corresponds to the area under the cumulated annual frequency and thereby the full load hours in the bin and is calculated according to the equation

$$F_i = \int \frac{t_i - t_a}{t_i - t_N} dZ_t$$

eq. 2

where

F_i = full load hours in bin i

t_i = design indoor temperature

t_a = ambient temperature

t_N = design outdoor temperature

dZ_t = increase in cumulated number of hours in bin i

The operation conditions at the operation point in the centre of the bin are considered to calculate the ε value. The ε values of the singles bins are combined to a seasonal performance factor by the equation

$$\beta = \frac{\sum_{i=1}^i F_i}{\sum_{i=1}^i \frac{F_i}{\varepsilon_i}}$$

eq. 3

where

β = seasonal performance factor

F_i = full load hours in bin i

ε_i = efficiency factor in bin i

The nominator represents the total energy supplied to the building and the denominator represents the sum of the respective amount of energy required for the bin i. Thus an energetic weighting is performed to receive the seasonal performance factor. COP values are taken from manufacturer's data. If data are not available, diagrams with default values for the COP, the source temperature and the heating curve are provided.

Back-up energy is considered by determining the energetic fraction delivered by the back-up system and the back-up system efficiency. Three operation modes of the back-up system are taken into account, alternative operation, parallel operation and partly parallel operation,

which are described in more detail in chapter 3.4.2.

To consider a hot water requirement a fictive higher indoor temperature, corresponding to a higher energy requirement in the respective bin is calculated, so the hot water requirement is transferred to a heating requirement, which is treated in the same way as the original heating requirement. The calculation of the fictive indoor temperature is done by eq. 4

$$t_i' = t_i + \frac{b_{DHW} \cdot G_t}{b_h \cdot 365}$$

eq. 4

where

t_i' = fictive indoor temperature

t_i = design indoor temperature

b_{DHW} = full load hours for domestic hot water

G_t = heating degree days

b_h = full load hours for heating

In this way, the fraction for the hot water requirement can be given for every bin. Combined operation for hot water is not considered in the guideline.

Assessment:

The method is a good approach for the calculation of the heating systems, although there are some draw backs that should be included in detail:

- COP values are not based on results of standard test results but on manufacturers' data
- Auxiliary energies, storage and distribution losses are not explicitly included in the SPF calculation method but only in the following cost calculation. These energies are only taken into account, if already entirely included in the COP values. Manufacturers' data are normally based on standard testing, which included only partly these energies.
- Input and output temperature requirements of the hot water are not considered, only the energetic calculation of the hot water requirements. For different temperatures of the heating and the hot water systems, the difference in the COP values is not considered.
- Cyclic losses by part load calculation are not considered

2.2.2 HTA Lucerne detailed version

Scope:

The method was developed in the NTH project [4]. Systems taken into account are electrically driven monovalent heat pumps with single speed compressor for heating and hot water production. Alternate operation of systems can be treated with the method, as heating and hot water requirements are calculated separately and combined to an overall SPF by the respective energetic fractions. A combined operation is not considered. For heating calculation the heat sources ambient air and the ground for brine-to-water heat pump are described, for hot water production, exhaust air heat pump water heaters and brine-to-water heat pumps are taken into account.

Input data:

- annual frequency of the ambient dry bulb air temperature (for A/W)
- COP-values of the heat pump at three fixed operation points (A/W) or one operation point (B/W)
- operation temperatures of the heating systems at standard testing points
- Upper temperature limit for heating (only for calculation of weighting factors. If weighting factors are given the temperature limit is not needed)

Methodology:

The method uses 3 operation points, which are located at the standard testing points of EN 255-2 [16] (extended according to regulations of the Swiss national test centre WPZ Töss [26]). For an energetic weighting of the points a weighting factor based on the heating degree hours are evaluated. Correction of standard COP values to actual operation conditions of the supply temperature is done by a correction factor, which is derived from the assumption, that the exergetic efficiency stays constant near the testing point. Temperature correction factors derived by this approach can be taken from tables. The correction method is described in more detail in chapter 4.4.2.2.

Another correction factor is used to take into account storage and distribution losses. This allows the use of the standard testing points from EN 255-2 for the hot water operation as well, if measurements according to EN 255-3 [17] are not available. Storage losses have to be known to determine the correction factor.

Assessment:

The method is easy-to-use, since position of the operation points are fixed to the values of the standard testing points and therefore weighting factors could be provided as tabled values. Weather data of Zurich Kloten are applied; hence correction of operation conditions only can be done for the supply temperature. Weighting factors for other weather stations can be generated.

Thus little input data are required, and correction factors can be taken from tabled values, but it is still transparent, how the correction factors are calculated, so without tabled values, they could be produced by the user itself.

Some impacts, however, are not taken into account:

- Changing source temperatures in the case of ground-coupled heat pumps (even though it can only be evaluated with simulation programs)
- No consideration of additional auxiliary energies not included in standard testing (may become relevant for the source pump in brine-to-water systems)
- Restriction to monovalent systems, no bivalent or monoenergetic calculation is provided
- Supply temperature correction by constant Carnot factor might become inaccurate, if the operation conditions vary much from the standard conditions.

2.2.3 CEN/TC 228/WG 4

Scope:

The method is still a working paper and actually not entirely formulated. It shall cover electrically driven heat pumps for all sources, but actually only the air-to-water part is formulated. Hot water requirement is not considered. The description refers to the state of the paper described in [5]. The calculation method is to be implemented in the standard prEN

14335 [37]. The system boundary corresponds to that of the heat generator depicted in Fig. 29.

Input data:

- Standard rating points of the COP and the output capacity according to EN 255-2 [16]
- Design heat load of the building according to prEN 12831 [40]
- specific water capacity of the heating system
- correction factor C_D (corresponding to a cyclic degradation coefficient)

Methodology:

The method uses a 1 K bin resolution, even though only the COP and output capacity values of EN 255-2 [16] are taken into account, i.e. the testing points A-7/W50, A2/W35 and A7/W50 for air-to-water heat pumps. Based on these three testing points, the characteristic curve for a supply temperature of 50° C is interpolated. Based on this interpolation correction for operation temperatures is done. However, the method does not seem to be adequate for all heat pumps. To receive the values for other supply temperatures, constant factors are given to correct the values of the 50° C curve.

Since the operation points are taken in a 1 K bin resolution, no energetic weighting is performed. The method carries out a power balance, where the building load and the output capacity in the respective bin are balanced. The building load is linear in the ambient temperature reaching from the design heat load at design outdoor temperature to zero at the upper temperature limit for heating. In case of the lack of output capacity of the heat pump, a back-up system delivers the missing heating power. Operation modes of the back-up system (alternative, parallel, partly parallel) are not described yet.

The respective energy is evaluated by multiplying the power values with the total time of the bin, which is taken from the hourly values of the annual frequency of the dry bulb ambient air temperature. The electrical energy consumed by the heat pump, the back-up energy and the auxiliary energy is summed up in every bin. A seasonal performance factor is not calculated directly but total electrical consumption is an output, so the SPF can be calculated from these values.

Cyclic losses dependent on the load factor of the heating systems are taken into account on the basis of default values, which are derived from an approach of Nicolaas & Peitsman [39] and from measurement of J. Bernier [25]. Auxiliary energy not considered in the standard testing shall be taken into account, as well, but an approach is not formulated yet.

Assessment:

The method is still in the phase of a draft. Even though most of the physical impacts on the heat pump operation are considered, the approaches are not entirely formulated yet. Moreover it takes more effort to perform the calculation, since every bin has to be calculated. However, it is not secure that a better exactness is provided by the method, since missing data are inter- or extrapolated or correction factors are applied. The correction factors are partly empirical or taken from measurements and not in every case transparent for the user.

2.2.4 ASHRAE 116 in connection with ASHRAE 137

Scope:

The ASHRAE standard 116 [6] treats unitary air-to-air heat pump in only heating mode, so domestic hot water production is not covered by this standard. However, ASHRAE Standard 124 [48] treats water heating by heat pumps with desuperheaters and ASHRAE 137 [47] is a connection of heating and domestic hot water production by desuperheaters, which

combines the calculation method to deal with heating and hot water production, as well in simultaneous operation. ASHRAE 116 covers single as well as multi compressor units. Monoenergetic systems with resistance heating are considered, too.

Input data:

Some input data depend on the climatic region and can be concluded from the site and taken directly from tables given in the standard.

The following input data are required:

- Climatic region
- Design building load
- Cyclic degradation coefficient C_D (evaluated from testing according to ARI 210/240 [24])
- Output capacity and electrical input from standard testing (testing points 47°F(8.33°C), 35°F(- 1.67°C), 17°F(- 8.33°C))
- If required, defrost control values F_{def} (evaluated by defrost test according to ARI 210/240)

Methodology:

As basis for the calculation the whole area of the USA is divided into 6 characteristic climatic conditions, for which the considering design outdoor temperature, heating load hours and fractional bin hours are provided in tables.

Fractional bin hours correspond to the weighting factors in the method of HTA Lucerne. However, the equation to produce these factors is not provided in ASHRAE 116.

The method applies a bin approach of max. 18 bins (5°F resolution (equals 2.7°C)), but dependent on the climatic region, the fractional bin hours in the lower temperature bins are zero, so these bins have no contribution to the SPF. As consequence the considered bins are in the range of 9 to 18 depending on the climatic region.

ASHRAE 116 applies a power balance for the heating seasonal performance according to the eq. 5

$$HSPF = \frac{\sum_{j=1}^{18} n_j \cdot BL(t_j) \cdot F_{def}}{\sum_{j=1}^{18} n_j HLF(t_j) \delta(t_j) \dot{E}(t_j) / PLF(t_j) + \sum_{j=1}^{18} RH(t_j)}$$

eq. 5

where

HSPF = the seasonal performance factor for heating

t_j = temperature of the respective bin j

$BL(t_j)$ the building load of the temperature bin j [Btu/h/1000],

F_{def} = defrost factor (derived from testing according to ARI 210/240 [24])

HLF = heating load factor

$\delta(t_j)$ = factor [0..1] to consider the fraction of monoenergetic operation

$\dot{E}(t_j)$ = electrical power input

PLF = part load factor

RH = electrical input by a resistance heater in monoenergetic operation

n_j = fractional bin hours of the respective bin

The nominator describes the building load at each temperature bin with a correction factor for the defrost control, if installed. The denominator describes the respective total electrical power input to cover the building load for each temperature bin j , the first term the fraction, that is required by the heat pump operation, the second term the power input to an installed back-up resistance heater.

The design heat load for the building is corrected with an experience factor (given with 0.77) to improve agreement with measured data. Bin building loads are derived with the linear equation

$$BL = \frac{65[^\circ\text{F}] - t_j}{65[^\circ\text{F}] - t_{OD}} \cdot 0.77 \cdot \text{DHR}$$

eq. 6

where

BL = building load

t_j = bin outdoor temperature

t_{OD} = outdoor design temperature

DHR = design heating requirement

The output capacity and the electricity input are determined by linear interpolation between the testing points. The output capacity of the heat pump is only needed to calculate the heating load factor HLF of the bin.

The heat pump low temperature cutout factor $\delta(t_j)$ characterises the monoenergetic operation. In the temperature range between the low cutout temperature for the heat pump and the balance temperature, $\delta(t_j)$ is set to 0.5, i.e. the heat pump and the back-up each contribute one half of the energy demand, below the low temperature cutout, $\delta(t_j)$ is 0 and for temperature above the balance point, $\delta(t_j)$ is 1.

The part load factor PLF is determined by the “cyclic degradation coefficient” C_D , which is delivered by the cyclic test according to ARI 210/240 [24]. A more detailed comparison of part load approaches is discussed in chapter 4.5.

ASHRAE 137 combines the method of ASHRAE 116 with a desuperheater calculation method. The method of ASHRAE 137 treats as well simultaneous operation of either heating and domestic hot water production or cooling and domestic hot water production. The definition of the SPF for combined heating and hot water, called CPF (combined performance factor), is given by eq. 7

$$\text{CPF}_{\text{hs}} = \frac{\sum_{j=1}^8 \left(\frac{q(t_j)}{N} + \frac{q_w(t_j)}{N} \right)}{3.413 \left[\frac{\text{Btu/h}}{\text{W}} \right] \sum_{j=1}^8 \left(\frac{E(t_j)}{N} + \frac{ER(t_j)}{N} + \frac{RH(t_j)}{N} \right)}$$

eq. 7

where

q = heating load [Btu/h]

t_j = temperature in bin j

q_w = hot water load during the total temperature bin hours N in the space and water heating season

E = electrical energy input to the heating, which includes the pump of the desuperheater [W]

ER = input energy supplied to the resistance water heater

RH = electrical input to the resistance space heating.

N =number of hours in bin j

The distribution of the total heating requirement to the part produced in combined operation is done by an evaluation of the actual heating and hot water load in the bin. The lower of both loads determines the partition of combined operation. Operation in single heating or hot water mode is calculated according to ASHRAE 116 or ASHRAE 124 [48] respectively.

Assessment:

ASHRAE 116 by itself delivers an SPF for single heating mode. Even though the scope of the method are air-to-air heat pumps, the calculation method seems to be transferable to other systems as air-to-water heat pumps and or ground- to-water heat pumps.

ASHRAE 116 is a comprehensive standard, since all physical factors relevant for the heat pump operation are taken into account in the standard. ASHRAE 137 extends this standard to combined operation. The distribution of the total requirement to single and combined operation respectively is done by the actual load factor. The smaller load factor of the two defines the fraction of combined operation.

However, this would be a maximum possible combined operation, as heating and hot water demand does not occur always at the same time, so real combined operation depends as well on control, tapping profiles and system design.

Moreover testing of the components is different from the testing in Europe, e.g. the values in ASHRAE, which are partly based on ARI testing methods, are different from the European testing result, and changes in the test procedure have to be introduced in the calculation method as well.

2.2.5 DIN 4702, part 8

Originally DIN 4702 [23] is a test method for the part load operation of boilers. However, with the rating point delivered by the standard, a seasonal performance calculation could be performed for boilers. As this calculation method has been developed as a quasi-standard for heat generation systems using boilers, a transfer of the methodology to heat pumps is made in [22]. The transfer is intended to deliver a comparison of different heating systems.

Input data:

Standard rating efficiency at 13%, 30%, 39%, 48%, 63% load.

Methodology:

The methodology resembles to the VDI 2067-6 [1]. The seasonal performance is calculated by the equation

$$SPF = \frac{5}{\sum_{i=1}^5 \frac{1}{\eta_i}}$$

eq. 8

where

SPF = seasonal performance factor of the generator

η_i = efficiency in bin i

which corresponds to eq. 3 for a defined weather data set. The position of five operation points corresponds to the load factors given in the test procedure. These load factors are determined in that way, that the related weighting factors, respectively the area under the cumulative frequency, are the same. Therefore the seasonal performance can be calculated by simply dividing by the number of operation points by the sum of the reciprocal values of the efficiencies at different load factors.

Assessment:

As the calculation of the seasonal performance factor according to DIN 4702, part 8 is a quasi standard for heating generator systems with boilers, the calculation is well suited for a comparison of different heat generators. However, the underlying meteorological data are fixed for a standard site and cannot be modified. Therefore an assessment of the performance of the same heating system for different sites cannot be evaluated. The SPF is calculated based on the measurement of the COP at defined load factors of the heating system, but no correction for auxiliary energy and energy parts not included in component testing are provided, e.g. storage losses. Bivalent systems can be considered by an energetic weighting. Therefore the method is suited to have a direct comparison of heat generators, but not for an assessment of system performance (system boundary limited to the generator). The method resembles the VDI calculation, but VDI is more variable for changing boundary conditions like meteo data.

2.3 Comparison of the found methods

To compare the results delivered by the existing calculation methods, a comparison of the found methods was performed for a commercial air to water heat pump on the basis of the buildings used in the STASCH project [19]. An overview of the input data for the calculation methods are given in Tab.1 and of the heating system in Tab. 2. DIN 4702, part 8 is not considered, as it resembles VDI 2067-6 [1] and the CEN method is in an early stage, yet.

Tab.1: Parameters of the heat pump for the comparison of calculation methods

Heat pump type SATAG AW 108 Hi (scaled)											
Testing points		A15/W35 (40% r.h.)	A10/W35 (78% r.h.)	A7/W35 (89% r.h.)	A2/W35 (93% r.h.)	A-7/W35 (75% r.h.)	A20/W50 (40% r.h.)	A15/W50 (71% r.h.)	A7/W50 (89% r.h.)	A2/W50 (93% r.h.)	A-7/W50 (75% r.h.)
Average output capacity	W	8380	6840	6400	5700	4520	7890	7180	6100	5470	4410
Average electrical power input	W	1683	1710	1716	1733	1759	2254	2272	2293	2308	2333
COP	-	4.98	4.00	3.73	3.29	2.57	3.50	3.16	2.66	2.37	1.89
Cyclic degradation coefficient	0.25 (taken from ASHRAE example calculation [6])										

Tab. 2: Parameters of the building and the site for the comparison of the calculation methods

Meteorological data	Design outdoor temperature	design load according to SIA 384/2 [9]	Heating curve	
			outdoor temp.	supply temp.
Stuttgart	-12 °C	5 KW	-11°C	35°C
			20°C	25.2°C

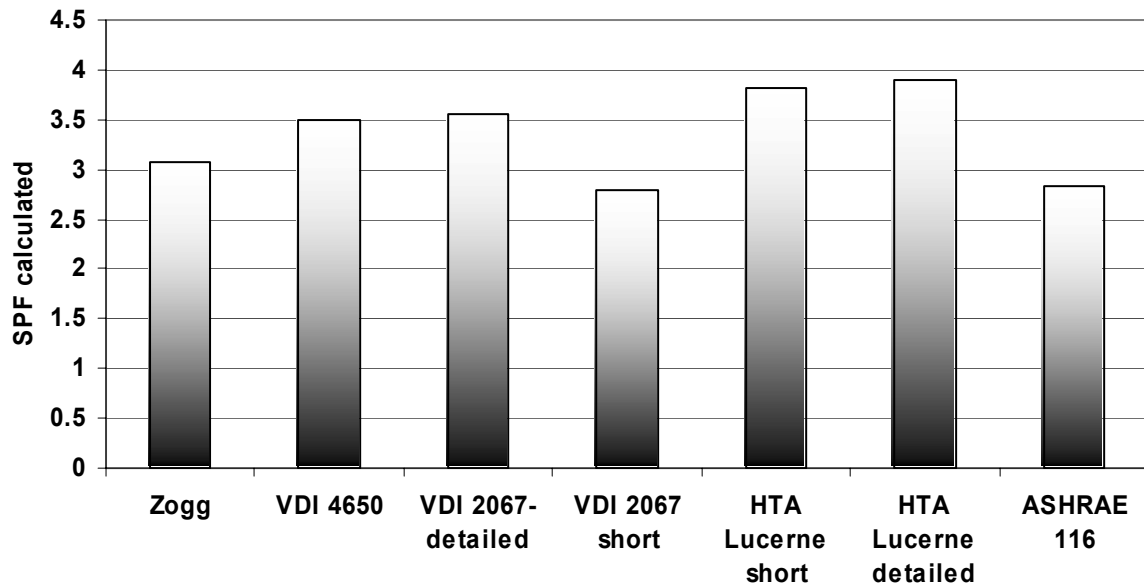

Fig. 1: comparison of the calculation methods (climate data of Stuttgart)

Both the method described by Zogg in [38] and the method VDI 2067 short [1] are based on empirical values. They only fit the system performance if the performance is comparable to an average standard of installed systems. Thus they cannot be used to assess the performance of a single system, as either no specific COP-values are considered or a market average is supposed. However, the methods are well suited to estimate the order of magnitude of the SPF. It is remarkable as well, that the calculation methods based on the empirical values deliver the lower SPF-values in comparison to the other methods. This can be explained by the system boundary, as VDI 4650, VDI 2067 - 6 and HTA Luzern do not take into account additional auxiliary energies. Only the ASHRAE 116 method lies in the same range of the SPF.

VDI 4650 [2] takes into account three COP-values for air-to-water systems and applies correction factors to these COP values to consider the operation conditions. HTA Lucerne short uses default values to correct for the temperature and meteorological data, while these values are calculated in the detailed version. In HTA Lucerne detailed method, meteo data are corrected by evaluating the heating degree hours of the site, and for the correction of the temperature, constant exergetic efficiency is assumed. This approach is described in more detail in chapter 4.4.2.2. That explains the discrepancy between the two methods. VDI 2067 - 6 detailed version [1] performs a similar calculation as HTA Lucerne, but the correction for the temperature is done by interpolation, which leads to the deviation of the delivered SPF.

ASHRAE 116 is the only method, which considers losses by cyclic operation and therefore delivers values below the other methods.

The comparison was carried out for Stuttgart, since VDI 4650 uses correction factors for different climates in Germany, which cannot be evaluated for other sites, e.g. in Switzerland. Therefore, the other methods were evaluated for the site Stuttgart.

2.4 Conclusion of the Survey

The following conclusion can be drawn from the survey of the examined international calculation methods.

2.4.1 Scope of the method in international standardisation

No method for the calculation of seasonal performance factor of heat pumps with combined space heating and DHW operation was found on the European level. However, CEN/TC 228/WG 4 is working on a calculation method which will deliver the electrical energy input and can thus be used to calculate the seasonal performance factor, too. It is to be integrated in the European standard prEN 14335 [37].

All calculation methods found in national standards or guidelines are limited in some way. Either only heating is taken into account or hot water operation is limited to alternate operation. Combined operation is only considered in the ASHRAE standards for air-to-air heat pumps with desuperheater. However, the found methods in the national standards could be extended or transferred to combined operation, if further standard testing points to characterise of the combined operation are available. Combined operation has a significant impact on the heating capacity and the COP of the heat pump. A test procedure suited for the combined operation of systems with condensate subcooling is developed at WPZ Töss based on the European standard test procedures EN 255-2 [16] and EN 255-3 [17] in the SFOE project "heat pump test for combined space heating and hot water production" [7]

2.4.2 Bin method

All considered existing hand calculation methods of the third category use a bin approach on the basis of hourly values of the ambient dry bulb air temperature to characterise the heating requirement for the heating mode operation. To evaluate the seasonal performance of the system, an energetic weighting of the bins is performed. It seems to be the best suited method for a hand calculation, as other methods are either less exact (first and second category of the found methods) or too complicated for a hand calculation (simulation programs).

2.4.3 Energy approach vs. power balance

The two basic formulations for the seasonal performance factor found in the international standardisation use some kind of energy balance or power balance.

In the European standardisation, both the building design heat load and the annual energy consumption for heating are calculated. The design load calculation is carried out according to prEN 12831 [40], in Switzerland being introduced by a revision of the Swiss national standard SIA 384/2 [9]. The annual energy consumption is calculated according to SIA 380/1 [8], which is the Swiss national standard derived from the European standard EN 832 [41].

Design building load according to prEN 12831 is intended for the dimensioning of the heat generator system. Thus the value is adapted to meet the heating requirements of the coldest day. Internal gains are only partly and external energy gains are not considered. As coldest days do not occur very often over the year (see chapter 4.1 on meteorological processing of annual frequency of the ambient temperature), the energy consumption of the building will be less than the design heat load implies. That is the reason, why in ASHRAE standard 116 [6] a correction factor of 0.77 is introduced to improve the agreement of calculated and measured values of building loads.

Methods using the building load apply a power balance to determine the electrical input. If the heat pump cannot meet the heat demand of the building, the difference is delivered by the back-up system. Thereby the amount of electrical power input and the heat load of the building are transferred to energies by multiplying with the bin time or weighted with a weighting factor and summed up over the year. The relation between the used heat energy and the total electrical input describes the seasonal performance, as it is done in eq. 5.

The energetic calculation according to SIA 380/1 provides a detailed energy balance for the building, which takes into account thermal bridges, heat losses, but as well internal and external gains based on monthly standard weather data of the site, so the energetic values are supposed to come closer to the real energy consumption of the building. Methods using the energy evaluate the heating degree hours of the site. Heating degree hours are considered proportional to the energy consumption of the building. The fraction of the heating degree hours of a respective bin in relation to the total heating degree hours deliver a weighting factor for the energy consumption of the building in the respective bin. Back-up energy is evaluated by given temperatures, the balance point and/or the lower cutout temperature, where operation of back-up takes place.

As the calculation method to be developed in this project intends to calculate the seasonal performance factor of the heating system – find the system boundaries definition in chapter 3.1 - which the operator can expect from the system, the value from the energy requirement calculation seems to be more suited than the design heat load.

Tab. 3: Overview of existing calculation methods in standards and directives

Criteria	VDI 2067-6	HTA Lucerne	CEN/TC228/WG4	ASHRAE 116
Scope	Electrically driven combustion engine driven Air-to-water, ground-to-water (horizontal collector), Water-to-water	Electrically driven Air-to-water, ground-to-water (U-tube vertical collector)	Electrically driven Air-to-water	Electrically driven heat pump Air-to-air
Method	Bins of ambient temperature	Bins of ambient temperature	Bins of ambient temperature	Bins of ambient temperature
Operation points	Arbitrary, recommendation 4 points	3, standard testing points A-7, A2, A7; B0 in ground-to- water systems	1 K bins	Dependent on climatic region, Max. 18 bins
systems	Bivalent	monovalent	bivalent	Monoenergetic
Consideration of DHW	Yearly amount of energy for hot water production	Daily amount of energy	No hot water calculation to be considered in separate part or standard	No hot water calculation; DHW production by desuperheater is considered in ASHRAE 124 and combined in ASHRAE 137
Source temperature	A/W: meteo data B/W: diagram with source temperature distribution	A/W: meteo data B/W: constant temperature	Meteo data	Meteo data

Tab. 3: Overview of existing calculation methods in standards and directives (continued)

Criteria	VDI 2067-6	HTA Lucerne	CEN/TC228/WG4	ASHRAE 116
Sink temperature	Evaluation of heating curve	Evaluation of heating curve	Evaluation of heating curve	Calculation at fixed steps
Calculation energy requirement	<p><u>Heating:</u> Relative heating degree hours (weighting factors)</p> <p><u>DHW:</u> yearly amount of energy transformed to a fictive higher indoor temperature (see description in chapter 2.2.1)</p>	<p><u>Heating:</u> Heating degree hours</p> <p><u>DHW:</u> Daily energy amount</p>	<p><u>Heating:</u> heating load linear in ambient temperature multiplied with bin hours</p>	<p><u>Heating:</u> heating load linear in ambient temperature multiplied with bin hours and correction factor of 0.77 to fit to experienced consumption</p>
Evaluation of output capacity/ COP values	Manufacturer data/ diagram with default values	Standard testing point according to EN 255-2 (WPZ Töss)	Standard testing points according to EN 255-2	No COP evaluation; evaluation of electrical energy consumption
Correction of output capacity/ COP values for operation conditions	Continuous curve of manufacturer/ default values	Correction for temperature impact with exergetic efficiency (see chapter 4.4.2.2)	Interpolation on the basis of two testing points	Linear interpolation between testing points
Consideration of part load	Cyclic operation at part load not taken into account	Cyclic operation at part load not taken into account	Correction with default degradation coefficient dependent on the used compressor/ default values dependent on the heating system	Consideration of part load by cyclic degradation coefficient evaluated from test procedure according to ARI 210/240
Consideration of auxiliary energy	Not explicit consideration of auxiliary energy, only if included in COP values	Only auxiliaries included in COP value according to standard testing	Constant fraction dependent output capacity	No explicit consideration of auxiliary energy
Consideration of back-up	weighting with energy fractions delivered by the respective systems	No bivalent systems	Electrical power balance	Electrical power balance

3 PRINCIPLES OF THE FHBB-METHOD

3.1 System boundaries

As this project is a national contribution to the IEA HPP Annex 28 the system boundary correspond to the system boundary described in the Annex text [31]. This system boundary is marked in Fig. 2.

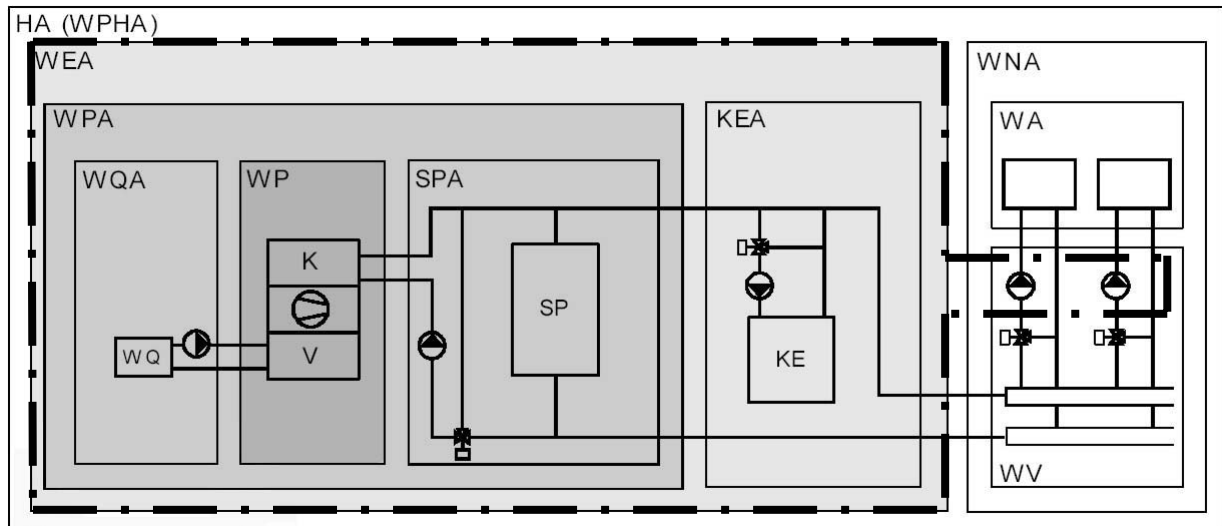

Fig. 2: System boundary definition (source [13])

where

HA (WPHA) = (heat pump) heating system

WEA = heat generation system (heat pump system and back-up)

WPA = heat pump system (including buffer storage)

WQA = heat pump source system

WP = heat pump

SPA = storage system

KEA = back-up system

WNA = heat utilisation system (heat distribution and heat emission)

WV = heat distribution system

WA = heat emission system

The system boundary to calculate the overall seasonal performance factor SPF_{sys} corresponds to the boundary "heat production system" (WEA) (— • —) from the RAVEL definition [13], i.e. the generation part including the source, the storage and the back-up system are inside the system boundary, the distribution and emission system are excluded. Contrary to the RAVEL definition [13], the circulation pump is included in the system boundary.

Based on the system boundary shown in Fig. 2 for this project the following effects are taken into account for the calculation of the SPF:

- type of the heat pump (air-to-water, liquid-to-water)
- heating and domestic hot water requirement
- effects of variation of source and sink temperature on output capacity and COP
- effects of part load operation (cyclic losses)
- auxiliary energy needed to operate the system, which is not considered in standard testing of output capacity and COP according to EN 255
- energetic fraction delivered by the back up systems depending on the operation mode

For the above system boundaries the following characteristic numbers can be defined:

Efficiency Factor ε :

$$\varepsilon = \frac{\phi_{hp}}{P_{com}}$$

eq. 9

where

ϕ_{hp} = output capacity of the heat pump

P_{com} = electrical power input to the compressor

Coefficient of Performance (according to EN 255-2 [16])

$$COP = \frac{\phi_{hp}}{P_{com} + P_{eva} + P_{con} + P_{ctrl} + P_{car}}$$

eq. 10

where

ϕ_{hp} = output capacity of the heat pump

P_{com} = electrical power input to the compressor

P_{eva} = electrical pumping power input to overcome the friction losses of the evaporator

P_{con} = electrical pumping power input to overcome the friction losses of the condenser

P_{ctrl} = electrical power input to control device

P_{car} = electrical power input to the carter heating

Seasonal Performance Factor (corresponds to system boundary “heat pump system” WPA including the circulation pump) of a monovalent heat pump system

$$SPF_{hp} = \frac{Q_{bl} + Q_{DHW}}{W_{hp} + W_{aux}}$$

eq. 11

where

SPF_{hp} = seasonal performance factor of the heat pump (without consideration of back-up)

Q_{bl} = energy requirement of the building

Q_{DHW} = domestic hot water energy requirement

W_{hp} = electrical energy input to heat pump

W_{aux} = additional auxiliary energy input not included in the COP definition (source pumping, sink pumping, storage loading)

Overall Seasonal Performance Factor (corresponds to system boundary WEA)

$$SPF_{sys} = \frac{Q_{bl} + Q_{DHW}}{\frac{\delta_{hp,bl} \cdot Q_{bl}}{SPF_{hp,h}} + \frac{\delta_{hp,DHW} \cdot Q_{DHW}}{SPF_{hp,DHW}} + \frac{(1 - \delta_{hp,bl}) \cdot Q_{bl}}{\eta_{bu,bl}} + \frac{(1 - \delta_{hp,DHW}) \cdot Q_{DHW}}{\eta_{bu,DHW}}}$$

eq. 12

where

SPF_{sys} = system seasonal performance factor (with consideration of back-up)

Q_{bl} = total building energy requirement

Q_{DHW} = total domestic hot water energy requirement

$\delta_{hp,bl}$ = fraction of building energy requirement covered by the heat pump

$\delta_{hp,DHW}$ = fraction of DHW energy requirement covered by the heat pump

$\eta_{bu,bl}$ = efficiency of the space heating back-up heater

$\eta_{bu,DHW}$ = efficiency of the DHW heating back-up heater

3.2 Input data for the calculation of the SPF

The following input data are required to carry out the calculation

- Meteorological data of the site
 - hourly values of ambient dry bulb temperature, e.g. from Meteonorm [10]
 - design outdoor temperature Θ_{OD}
- Design values of the heating system
 - heating energy requirement (e.g. according to SIA 380/1 [8] or EN 832 [41])
 - design heat load (e.g. according to SIA 384/2 [9] or prEN 12831 [40])
 - upper ambient temperature for heating Θ_{ulh}
 - operation mode of the back-up system
 - balance point Θ_{bp} (for bivalent systems)
 - lower cutout temperature of the heat pump Θ_{itc} (in case of bivalent partly parallel operation)
 - heating characteristic curve (dependency supply temperature on ambient temperature)
- heat pump parameters:
 - heating capacity according to EN 255
 - COP-values according to EN 255
- design values of the domestic hot water system
 - domestic hot water energy requirement (calculated e.g. according to SIA 385-3 [29] or according to VSSH [30])

- supply temperature hot water Θ_{hw}
- inlet temperature cold water Θ_{cw}
- parameter of the storage system (heat-loss [W/K] or surface and heat loss coefficient [W/m²K])
- hourly values of the source temperature (in case of air e.g. the ambient dry bulb temperature)

If not all required input data are available, an Annex to the calculation method could provide default values, which are oriented at the lower end of the available products on the market. By this concept the method can be carried out in every case, but it is worth providing the real data, because they will probably deliver better results. This procedure is well established in European standardisation.

3.3 Calculation procedure of the FHBB-method

The calculation procedure follows the well-established bin method, which is used in different standards to calculate the seasonal performance as discussed in detail in chapter 3.3.1. This bin method is extended to cover the combined operation mode, as well. Basis for the calculation of the combined operation mode is adequate component testing (see details in [7]), which delivers the required characteristic of the COP and the output capacity of the heat pump and which is essential for the performance calculation.

3.3.1 Introduction to the bin method

The main idea of the calculation method can be described like that:

If one third of the total energy is produced with a seasonal performance factor of 300 % and two thirds are produced with 350 %, than the seasonal performance factor is 333%

So basically, the method evaluates two factors:

1. How much energy is produced in certain operation conditions?
 - Weighting factor representing an energetic weighting for the respective operation conditions
2. Determination of the operation conditions and the respective performance factor for this energetic fraction of the total energy requirement
 - Relevant performance for the respective amount of energy

Thus the bin method assumes, that operation conditions at the operation point are valid for the whole bin, i.e. the operation conditions characterises the mean operation conditions of the bin. Therefore the operation points are to be set in the centre of the bin. The larger the bin is chosen, the more the averaging effect will veil. However, the exactness of the solution cannot be improved arbitrarily. Investigations showed, that a resolution of five bins yields an SPF, which can only be improved by 1% by increasing the number of operation points (see chapter 4.4.2.4.). Therefore five uniformly spread operation points for the heating operation seem to be a good compromise between exactness and calculation time. The resolution of operation points depends on the quality and quantity of available data of the output capacity

and the COP of the heat pump, as well. It does not make much sense to have 20 operation points with only two measured COP values.

The determination of the energetic fraction is done by the evaluation of the cumulative heating degree hours, derived from the hourly annual frequency of the ambient dry-bulb air temperature. It is only dependent on the site, the design indoor temperature and the upper temperature limit for heating. The method to process the meteorological data of the site to the respective weighting factor is described in chapter 4.1.1 in detail.

Fig. 3 shows an example of the cumulated annual frequency and the distribution of the bins.

Referring to the definition in eq. 11 the performance factor of the respective bin is evaluated by taking into account the following energies for every bin:

- Building energy demand
- Energy losses by storage(s)
- Energy losses by cycling
- Additional auxiliary energies for the system operation, which are not included in the standard values according to EN 255-2 [16] or EN 255-3 [17] respectively.

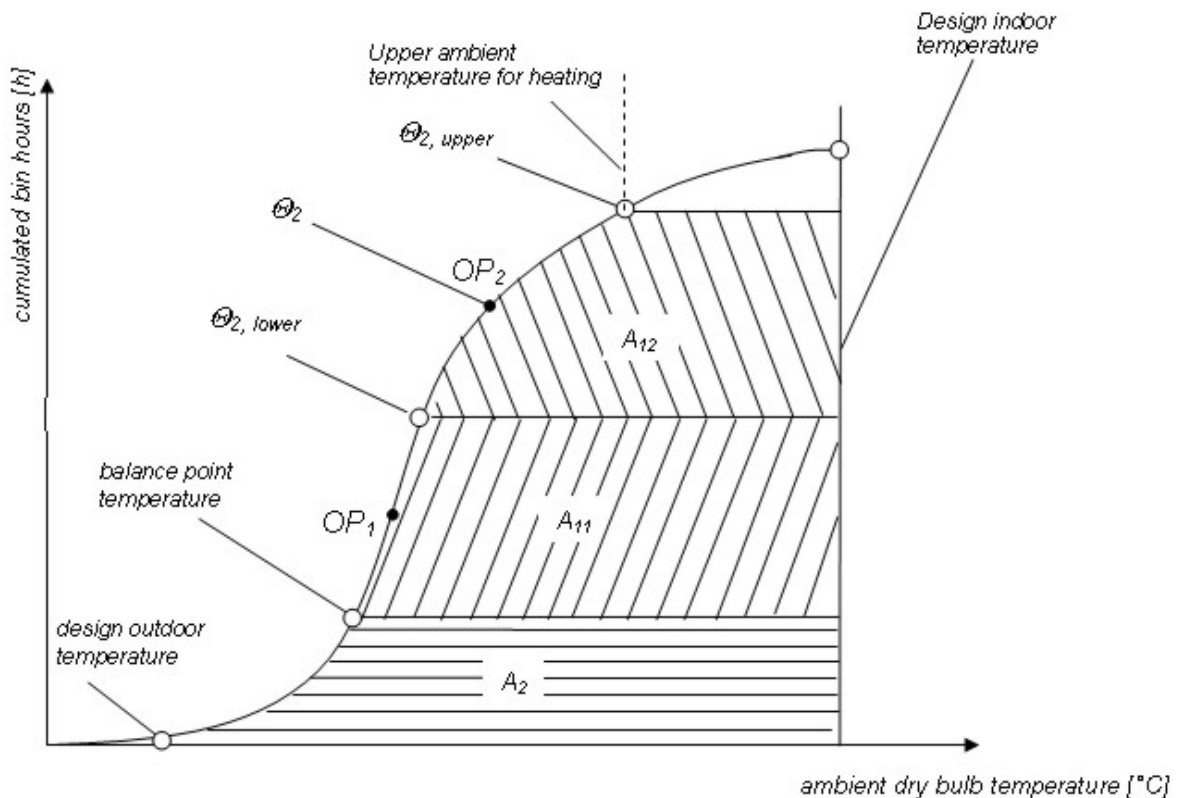

Fig. 3: cumulative frequency distribution of heating hours versus the ambient dry bulb temperature

After the calculation of each bin, a weighting with the weighting factor of the meteo data and the summation of the single bins is performed to receive the seasonal performance factor of the heat pump. Depending on the existence of a back-up system and its operation mode, a further weighting with energy fractions for heat pump and back-up operation is done to calculate the overall seasonal performance factor SPF_{sys} or the seasonal performance factor for space heating SPF_h only.

A similar calculation can be performed for the domestic hot water part of the system. For heat pump water heaters, only the hot water calculation is performed. Operation points for alternate operating systems should be the same as in the calculation of the heating part during the heating period, but operation takes place in the summer as well, so further bins have to be taken into account. Result of the hot water calculation is the seasonal performance factor for domestic hot water SPF_{DHW} . The two seasonal performance factors are combined by the energetic fractions.

For the combined operation mode a third SPF_{combi} has to be taken into account, which defines the performance in the combined operation mode. For the energetic weighting of the three numbers, the energetic fraction produced in single and combined operation respectively has to be determined.

3.4 Calculation method step by step

The calculation method is to handle different cases of heat pump systems for heating and/or alternate or simultaneous production of domestic hot water. Therefore, depending on the system considered, not all calculation steps described in the following have to be carried out for every system. Thus the steps are characterised by a letter and a number. The letter A, for instance, refers to single heating operation, which has to be applied for systems that only deliver space heating energy as well as in single operation mode in combined operating systems. B refers to single domestic hot water operation and C refers to calculations steps, that have to be performed for simultaneous operating systems. AB refers to the alternate combined operation, which can be concluded from the single calculations steps of mode A and mode B.

3.4.1 Preprocessing of the meteorological data

Basis for the calculation method are the meteorological data of the site. Meteo data have to be evaluated to receive the weighting factors for the respective bins. The preprocessing of the hourly meteorological data to deliver these weighting factors is described in chapter 4.1.1.

3.4.2 A - Heating mode

Step A1: Determination of the operation points

The operation points should be spaced uniformly over the whole operation range of the heat pump. Further on an investigation showed, that a resolution of five operation points approaches a limit, which is only improved slightly by a higher resolution of operation points. Fig. 17 in chapter 4.4.2.4 shows the impact of the number of bins on the calculated SPF.

Step A2: Determination of the yearly energy consumption

The energy values are needed to perform the weighting between different energetic fractions in the case of combined heating and domestic hot water operation. Moreover the running time of the heat pump is determined by the energy per bin divided by the actual output capacity of the heat pump. If the calculated heat pump running time is higher than the

number of bin hours, the back-up has to be operated.

In the case of new buildings the yearly energy consumption is available from the calculation according to SIA 380/1, the Swiss standard corresponding to the EN 832 [41] on the European level. In the case of existing buildings a measurement or an evaluation of the consumed energy of the last years yield a value for the energy consumption.

Step A3: Determination of source temperature at operation points

Air-to-water heat pumps

In the case of air-to-water heat pumps the source temperature corresponds to the ambient dry bulb air temperature and is given by the meteorological data.

Tab. 4: meteorological input data for the calculation method (example Zurich SMA derived from [10])

Ambient temperature [°C]	Annual frequency [h]	Cumulated bin hours [h]	Heating degree hours 20/15 [Kh/a]	Cumulative heating degree hours [Kh/a]	Weighting factor
-14	3	3	102	102	0.00
-13	16	19	528	630	0.01
-12	7	26	224	854	0.00
-11	8	34	248	1102	0.00
-10	18	52	540	1642	0.01
-9	21	73	609	2251	0.01
-8	34	107	952	3203	0.01
-7	23	130	621	3824	0.01
-6	34	164	884	4708	0.01
-5	35	199	875	5583	0.01
-4	51	250	1224	6807	0.01
-3	84	334	1932	8739	0.02
-2	158	492	3476	12215	0.04
-1	220	712	4620	16835	0.05
0	318	1030	6360	23195	0.07
1	511	1541	9709	32904	0.11
2	448	1989	8064	40968	0.09
3	361	2350	6137	47105	0.07
4	357	2707	5712	52817	0.06
5	346	3053	5190	58007	0.06
6	303	3356	4242	62249	0.05
7	341	3697	4433	66682	0.05
8	366	4063	4392	71074	0.05
9	329	4392	3619	74693	0.04
10	340	4732	3400	78093	0.04
11	390	5122	3510	81603	0.04
12	370	5492	2960	84563	0.03
13	345	5837	2415	86978	0.03
14	356	6193	2136	89114	0.02
15	379	6572	1895	91009	Σ 1

Brine-to-water heat pumps

In the case of brine-to-water heat pumps the source temperature is an input value. Source temperature depends on the thermal characteristics of the ground at the site and can only be evaluated by measurements or simulations. If measurements are available, they should be used. If measurements are not available, the software EWS [27] in connection with the ground properties from the program SwEWS [28] can produce an hourly temperature profile of the source temperature. The transformation from the time dependent hourly values to the temperature dependent values is difficult. One approach could be a regression, e.g. with the Solver Add-in in Excel.

Water-to-water heat pumps

In the case of water-to-water heat pumps surface water and ground water has to be differentiated. While the temperature of ground water does not change much over the season and can be considered as constant input temperature all over the year, the temperature profile of surface water however strongly depends on the ambient conditions and can hardly be predicted. It has to be evaluated by measurements or simulations as in the case of ground coupled heat pumps.

Step A4: Determination of values of the output capacity and the COP

For the determination of the COP values, standard measurements of WPZ-Töss according to EN 255-2 [16] (extended to 5 measurement point at two temperature levels according to the Töss reglement [26]) are used. Fig. 4 shows the measurement points of WPZ-Töss for different types of heat pumps. If no or not enough standard measurements of the respective heat pump are available from test centres, manufacturers' data can be used, but should be based on measurements according to EN 255-2.

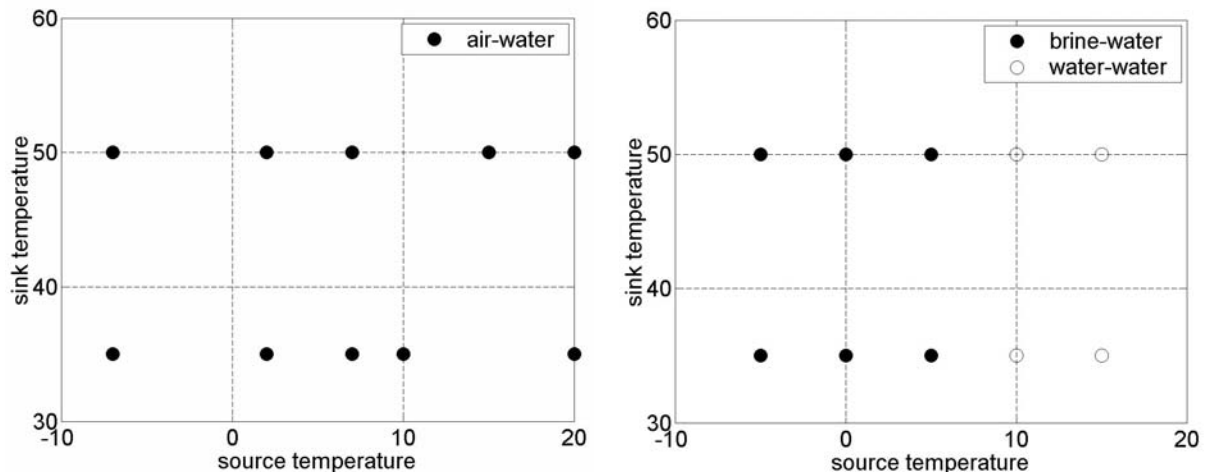

Fig. 4: measurement points for different types of heat pumps according to WPZ Töss Reglement [26]

Step A5: Correction of the standard steady-state COP-values

To take into account temperature impacts of changing source and supply temperatures on the standard output capacity and COP values, a linear inter- or extrapolation is applied. The supply temperature is taken from the heating characteristic curve of the heating systems which has to be given as an input value.

Step A6: Determination of heat losses due to cyclic operation (part load effects)

For the correction of part-load operation effects, additional information about the heat pump has to be provided. In the project "dynamic heat pump testing" [12] methods for the calculation of the heat generation degradation of the heat pumps due to cyclic operation have been developed. The necessary component characteristics can be derived from a developed test procedure [14]. However, no official standard testing of dynamic characteristics is provided in Europe at this time, so data might not be available. In the case that no testing is performed, default values dependent on the type of heat pump have to be used. According to an approach described by Shafai in [12] the losses per cycle can be calculated by

$$Q_{l,cyc} = Q_{l,cyc,max} \cdot f_{dyn}$$

eq. 13

where

$Q_{l,cyc}$ = heat loss due to cyclic operation of the heat pump in one cycle

$Q_{l,cyc,max}$ = maximum heat loss due to cyclic operation of the heat pump in one cycle

f_{dyn} = dynamic correction factor

Different approaches for cyclic losses are described in detail in chapter 4.5. With the losses per cycle, the total energy loss in the bin can be calculated by eq. 14

$$Q_{l,cyc,i} = Q_{l,cyc} \cdot n_{cyc,i}$$

eq. 14

where

$Q_{l,cyc,i}$ = cyclic losses in the bin

$Q_{l,cyc}$ = heat loss due to cyclic operation of the heat pump in one cycle

$n_{cyc,i}$ = number of cycles in the bin

Details of the calculation of $Q_{l,cyc}$ are described in chapter 4.5.1. The number of cycles depends on the system configuration. In systems with heating storage – in serial or parallel configuration - the cycles are determined by the heating load and the characteristic of the storage. If no storage is integrated, cyclic operation depends on settings of a two-point controller (hysteresis), the inertia of the heat distribution system and blocking time of the electrical supply. For air-to-water heat pump, defrost cycles have a further impact.

Cyclic losses have an impact on the running time of the heat pump, since cyclic losses reduce the steady-state output capacity of the heat pump. The running time itself is an input for the calculation of cyclic losses, so depending on the influence of the dynamic fraction an iterative solution has to be applied. However in well-designed systems or in case of a high inertia of the emission system the iteration can be avoided since cyclic operation is reduced.

Step A7: Determination of system heat losses

Storage losses have to be covered by the heat pump, so losses of the storage have to be taken into account to evaluate the energy which has to be produced by the heat pump. If a heating buffer storage is included in the heating circuit, the losses of the storage have to be calculated according to eq. 15

$$Q_{l,s} = U \cdot A \cdot (\Theta_{s,av} - \Theta_{s,env}) \cdot t_i$$

eq. 15

where

$Q_{l,s}$ = storage losses

$(U \cdot A)$ = heat loss [W/K]

$\Theta_{s,av}$ = average temperature of the storage fluid

$\Theta_{s,env}$ = temperature of the storage environment

t_i = time in bin i

Storage losses could be given directly as energy values [kWh/24h], e.g. like in the Swiss energy directive [51], where the nominal loss at 65°C/20°C has to be corrected to the corresponding bin temperature difference, or as heat loss [W/K]. The heat loss values are usually included in the manufacturer data of the storage or are evaluated in storage testing, e.g. according to DIN V 4357-8 [42].

Step A8: Determination of the running time of the heat pump

Running time of the heat pump is needed to evaluate additional auxiliary energy input. Running time can be evaluated by eq. 16

$$t_{op,i} = \frac{Q_{hp,t,i}}{\phi_{hp,i}}$$

eq. 16

where

$t_{op,i}$ = operation time of the heat pump

$Q_{hp,t,i}$ = total produced heat energy of the heat pump (used energy and losses)

$\phi_{hp,i}$ = heating output capacity of the heat pump

The total produced heat energy of the heat pump can be calculated by adding the used energy of the building (input data according to SIA 380/1 [8]) and the storage and cyclic losses, that are calculated according to eq. 15 and eq. 14 respectively.

Step A9: Determination of auxiliary energy

According to eq. 10 parts of the auxiliary energy consumption are already included in the COP values according to EN 255-2, so only the additional auxiliary energy consumption is to be taken into account here. The COP according to EN 255-2 includes the electrical energy for control devices, the pumping energy to overcome the internal pressure drop in the condenser and the evaporator and electrical supplementary heating devices, if existent. Defrosting during test cycles is taken into account, as well.

The electricity input to auxiliaries can be derived from rated power of the respective auxiliary component and its running time according to

$$W_{aux} = \phi_{aux} \cdot t_{op,aux}$$

eq. 17

where

W_{aux} = electricity energy input to auxiliary component

ϕ_{aux} = rated electrical power of the auxiliary component

$t_{op,aux}$ = operation time of the auxiliary component

The electrical power already included in the COP according to EN 255-2 [16] can be calculated by the equation

$$\phi_{\text{aux,int}} = \frac{\Delta p \cdot \dot{V}}{\eta_{\text{aux}}}$$

eq. 18

where

$\phi_{\text{aux,int}}$ = fraction of the electrical power already included in the COP value

Δp = pressure drop in the respective component, i.e. the evaporator or the condenser

\dot{V} = rated volume flow through evaporator or condenser

η_{aux} = pump efficiency of the auxiliary component

The values for the pressure drop of the evaporator and the condenser are measured during the component testing according to EN 255-2 [16] and the rated volume flow is given by the manufacturer. The pump efficiency is set to $\eta_{\text{aux}} = 0.3$ in EN 255.

Thus the additional external power not included in the COP value can be calculated according to

$$\phi_{\text{aux,ext}} = \phi_{\text{aux}} - \phi_{\text{aux,int}}$$

eq. 19

where

$\phi_{\text{aux,ext}}$ = external auxiliary power

$\phi_{\text{aux,int}}$ = fraction of auxiliary power included in the COP according to EN 255

ϕ_{aux} = rated power of the auxiliary component

The running time of the auxiliary components depends on the control strategy and system configuration. Circulation pumps of the heating cycle usually run through the whole heating period, while the running time of source pumps is usually associated to the running time of the heat pump. If a heating buffer storage is integrated in the cycle, the storage loading pump is associated to the running time of the heat pump. The running time of the heat pump of the respective bin can be calculated by eq. 16

The running time of the components that run through the whole heating period can be evaluated by the bin time, which can be taken from the table of the meteorological data. An example for Zurich SMA is given in *Tab. 4*.

Step A10: Calculation of bin performance factors

With the data calculated in the previous steps, the bin performance factor of the respective bin can be calculated according to eq. 20

$$PF_i = \frac{Q_{\text{bl,hp,i}}}{\frac{Q_{\text{bl,hp,i}} + Q_{\text{l,cyc,i}} + Q_{\text{l,s,i}}}{COP_i} + W_{\text{aux,i}}}$$

eq. 20

where

$Q_{\text{bl,hp,i}}$ = bin building energy demand covered by heat pump

$Q_{\text{l,s,i}}$ = bin storage losses

$Q_{\text{l,cyc,i}}$ = bin losses of the heat pump due to cyclic operation

$W_{\text{aux,i}}$ = bin electrical auxiliary energy

COP_i = COP at the operation point taken as performance of the heat pump in the bin

Note: frost/defrost losses of air-to-water heat pumps are already included in the COP-values according to EN 255 [16].

Step A11: Weighting of the bin performance factors to the SPF heating

With the bin performance factors the seasonal performance of the heat pump can be calculated according to eq. 21

$$SPF_{hp,h} = \frac{\sum_i Q_{bl,hp,i}}{\sum_i W_i} = \frac{\sum_i Q_{bl,hp,i}}{\sum_i \frac{Q_{bl,hp,i}}{PF_i}} = \frac{1}{\sum_i \frac{Q_{bl,hp,i}}{\sum_i Q_{bl,hp,i} PF_i}} = \frac{1}{\sum_i \frac{w_i}{PF_i}}$$

eq. 21

where:

$SPF_{hp,h}$ = system seasonal performance factor of the heat pump in heating operation

$Q_{bl,hp,i}$ = building energy demand in bin i covered by heat pump

PF_i = bin performance factor in bin i

w_i = energetic weighting factor in bin i

W_i = electricity consumption

The weighting factor w_i of the respective bin can be calculated by eq. 22

$$w_i = \frac{Q_{bl,hp,i}}{Q_{bl,hp,t}} = \frac{HDH_{\Theta,upper,i} - HDH_{\Theta,lower,i}}{HDH_{t,hp}}$$

eq. 22

where

$Q_{bl,hp,i}$ = heating energy requirement covered with the heat pump in bin i

$Q_{bl,hp}$ = total heating energy requirement covered with the heat pump

$HDH_{t,hp}$ = total heating degree hours covered by the heat pump operation

$HDH_{\Theta,upper,i}$ = heating degree hours to the temperature at the upper end in bin i

$HDH_{\Theta,lower,i}$ = heating degree hours to the temperature at the lower end in bin i

The heating degree hours of the respective temperatures can be taken from the table of the meteorological data (see Tab. 4). The total heating degree hours covered by the heat pump operation can be evaluated according to equation eq. 23

$$HDH_{t,hp} = HDH_t \cdot \delta_{hp}$$

eq. 23

where

$HDH_{t,hp}$ = heating degree hours covered with the heat pump

HDH_t = total heating degree hours

δ_{hp} = energy fraction covered by the heat pump

The calculation of the fraction of the heat pump operation is treated in Step A 12 in connection with the weighting with back-up energy.

Step A12: Weighting of the SPF_{hp} of the heat pump with back-up energy

In case of bivalent systems, the SPF of the heat pump has to be weighted with the back-up energy to receive the system seasonal performance factor. Supplied back-up energy depends on the operation mode of the back-up system. Three operation modes can be differentiated:

Alternate operation

In alternate operation mode, the heat pump is switched off at the balance point and only the back-up system is running to cover the total heat demand.

As the total heat demand is covered by the back-up system, the back-up generator has to be dimensioned to the maximum heat demand. Therefore this operation mode is mostly used in retrofit system with high supply temperatures, where a generator of this power is already installed.

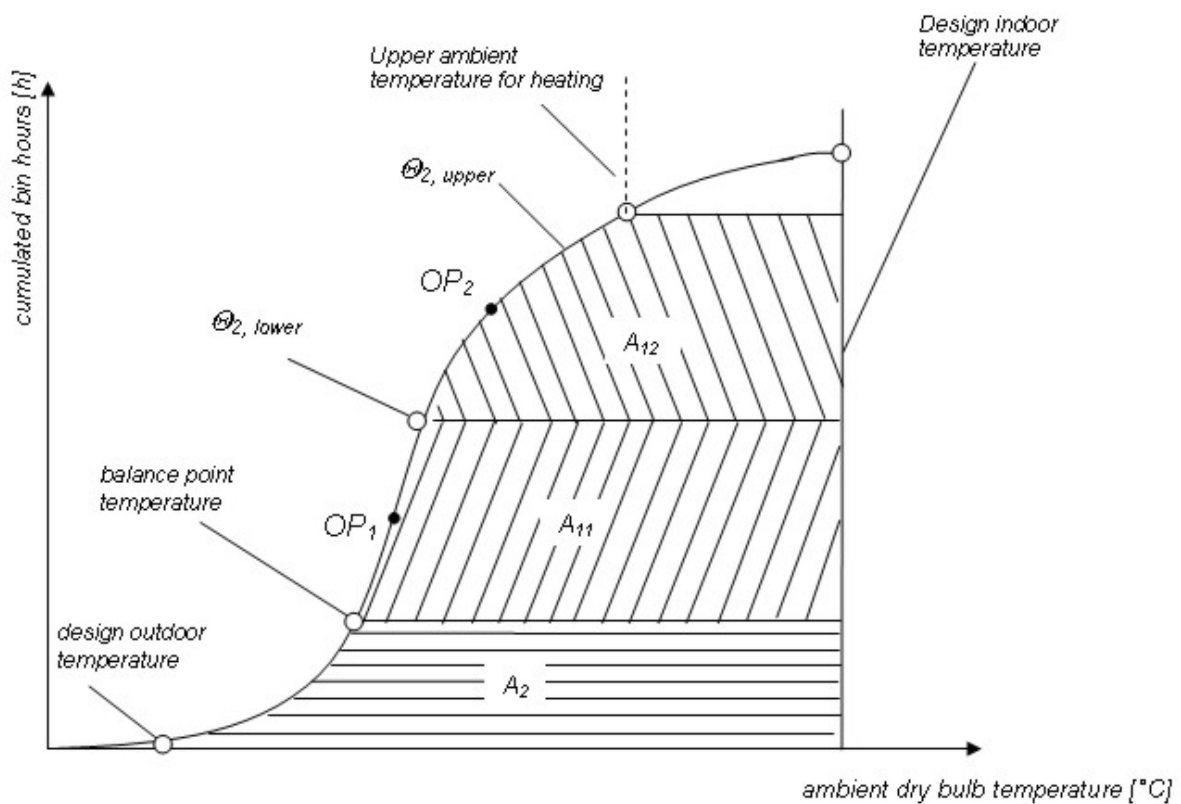

Fig. 5: alternate back-up operation mode

Fig. 5 shows the areas under the cumulative annual frequency of the ambient dry bulb temperature. The energetic fraction of the back-up energy, which corresponds to the ratio of the area A_2 to the total area, can be calculated according to eq. 24

$$\delta_{bu} = \frac{HDH(\Theta_{bp})}{HDH_t}$$

eq. 24

where

δ_{bu} = energy fraction covered by the back-up generator

$HDH(\Theta_{bp})$ = cumulated heating degree hours up to the balance temperature Θ_{bp}

HDH_t = total heating degree hours

The balance point is defined as point, where the building load equals the output capacity of the heat pump. In direction to lower outdoor temperatures, the output capacity of the heat pump is not sufficient to cover the building load and a second heat generator, the back-up generator, has to be operated (bivalent operation). In the direction of higher temperatures, the output capacity of the heat pump can cover the building load. The temperature of the balance point can thus be evaluated from the intersection of the design heat load and the output capacity of the heat pump described by the eq. 25

$$\phi_{bl}(\Theta_{bp}) = \phi_{hp}(\Theta_{bp})$$

eq. 25

where

ϕ_{bl} = heat load at the balance point temperature

ϕ_{hp} = output capacity of the heat pump at the balance point temperature

Θ_{bp} = temperature at the balance point

The values to evaluate the area in the cumulative frequency diagram, e.g. the heating degree hours, can be taken from the meteorological data (see Tab. 4).

Parallel operation

In parallel operation the heat pump is not switched-off at the balance point but operates at the rated heating output capacity. Only the building heat demand that cannot be covered by the heat pump is covered by the back-up system. This energetic fraction corresponds to the area A_2 in Fig. 6, which shows the cumulative annual frequency of the ambient dry bulb temperature for the back-up system in the parallel operation mode.

The respective energetic fraction represented by the area of the back-up energy can be calculated by

$$\delta_{bu} = \frac{HDH(\Theta_{bp}) - (\Theta_{ID} - \Theta_{bp}) \cdot n_{hours}(\Theta_{bp})}{HDH_t}$$

eq. 26

where

δ_{bu} = energy fraction of the back-up generator

Θ_{bp} = temperature at balance point

Θ_{ID} = indoor design temperature

$HDH(\Theta_{bp})$ = cumulated heating degree hours up to the balance point

$n_{hours}(\Theta_{bp})$ = cumulated bin hours up to the balance point

HDH_t = total heating degree hours

The respective values can be taken from the table of the meteorological data (see Tab. 4)

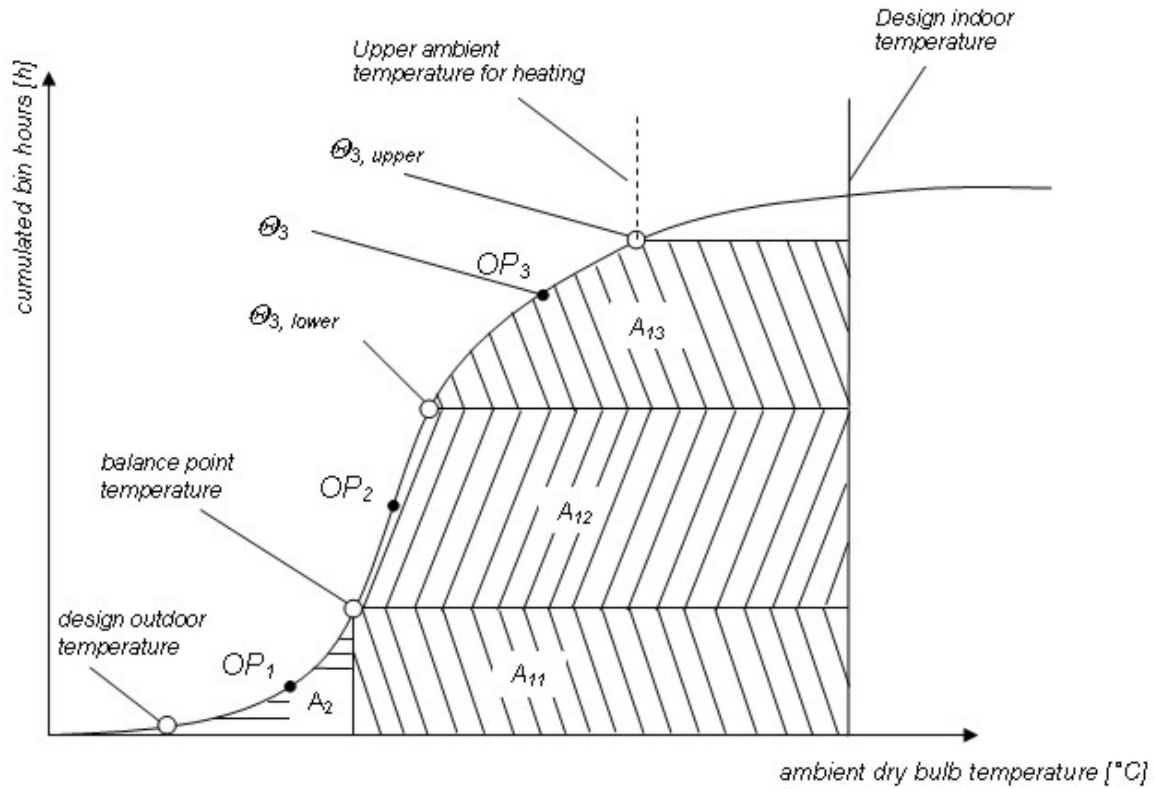

Fig. 6: Parallel back-up operation mode

Partly parallel operation

In partly parallel operation mode of the back-up system the back-up generator is switched-on at the balance point and the heat pump and the back-up system are operated in parallel until the lower cutout temperature for heating, at which the heat pump is switched-off and the back-up system supplies the total heat demand. Fig. 7 shows the areas at partly parallel operation mode in the cumulative annual frequency of ambient dry bulb temperature. The area A_2 corresponds to the energetic fraction of the back-up system.

This area can be calculated according to eq. 27

$$\delta_{bu} = \frac{HDH(\Theta_{bp}) - ((\Theta_{ID} - \Theta_{bp}) \cdot (n_{hours}(\Theta_{bp}) - n_{hours}(\Theta_{ltc})))}{HDH_t}$$

eq. 27

where

δ_{bu} = energy fraction of the back-up generator

$HDH(\Theta_{bp})$ = heating degree hours up to the balance point

Θ_{ID} = design indoor temperature

Θ_{bp} = temperature at balance point

Θ_{ltc} = lower cutout temperature of the heat pump

$n_{hours}(\Theta_{ltc})$ = cumulated bin hours up to the lower temperature cutout point

$n_{hours}(\Theta_{bp})$ = cumulated bin hours up to the balance point temperature

HDH_t = total heating degree hours

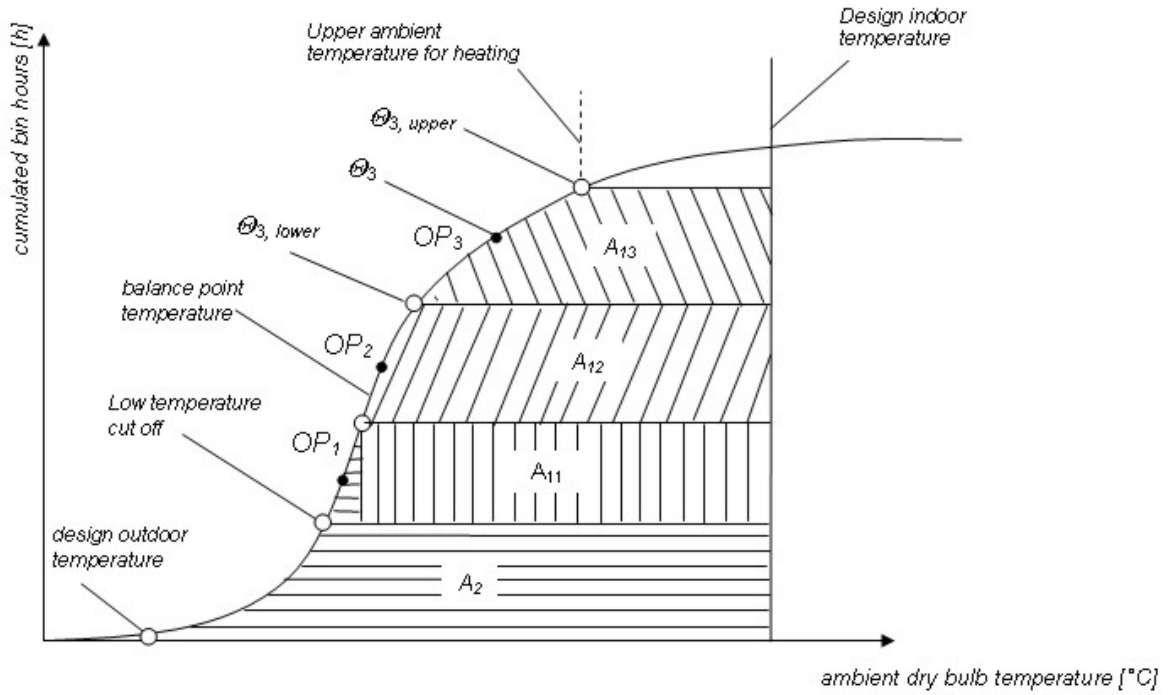

Fig. 7: Partly parallel operation mode of the back-up system

The system seasonal performance factor of the heating system is defined according to eq. 11 as

$$SPF_{sys} = \frac{\sum Q_{used}}{\sum W_{in}} = \frac{Q_{bl, hp} + Q_{bl, bu}}{W_{hp} + W_{bu}} = \frac{\delta_{hp, bl} Q_{bl} + \delta_{bu, bl} \cdot Q_{bl}}{W_{hp} + W_{bu}} = \frac{Q_{bl}}{W_{hp} + W_{bu}}$$

eq. 28

where

SPF_{sys} = system seasonal performance factor (heat pump and back-up)

Q_{used} = used heat energy

W_{in} = energy input, in case of electrical back-up electricity

W_{hp} = electricity input for the heat pump

W_{bu} = electricity input for the back-up system

$\delta_{hp, bl}$ = fraction of energy delivered by the heat pump

$\delta_{bu, bl}$ = fraction of energy delivered by the back-up

The electrical input equals the quotient of the used heat to the performance factor according to eq. 29

$$W_{hp} = \frac{\delta_{hp, bl} \cdot Q_{bl}}{SPF_{hp, h}}$$

eq. 29

where

W_{hp} = energy input for the heat pump system

$\delta_{hp,bl}$ =fraction of heat pump energy

Q_{bl} =building energy requirement

$SPF_{hp,h}$ = system seasonal performance factor of the heat pump in heating operation

and eq. 30 respectively

$$W_{bu} = \frac{\delta_{bu,bl} Q_{bl}}{\eta_{bu,bl}}$$

eq. 30

where

W_{bu} =energy input for the back-up system

Q_{bl} =building energy requirement

$\delta_{bu,bl}$ =fraction of back-up energy

$\eta_{bu,bl}$ = efficiency of the back-up system (for monoenergetic systems, $\eta_{bu,bl} = 1$)

As the energy is either produced by the heat pump or the back-up system, the total energy is the sum of the heat pump and the back-up energy, thus

$$\delta_{bu,bl} = 1 - \delta_{hp,bl}$$

eq. 31

where

$\delta_{bu,bl}$ = fraction of the used energy, delivered by the back-up system

$\delta_{hp,bl}$ = fraction of the used energy, delivered by the heat pump

Thus knowing the fraction of back-up energy the system seasonal performance factor can be calculated according to eq. 32

$$SPF_{sys,h} = \frac{Q_{bl}}{\frac{(1 - \delta_{bu,bl}) \cdot Q_{bl}}{SPF_{hp,h}} + \frac{\delta_{bu,bl} \cdot Q_{bl}}{\eta_{bu,bl}}}$$

eq. 32

where

$SPF_{sys,h}$ = system seasonal performance factor in space heating mode

$SPF_{hp,h}$ = seasonal performance factor of the heat pump in space heating mode

Q_{bl} = total building energy demand

$\delta_{bu,bl}$ = fraction of building energy demand covered by the back-up heater

$\eta_{bu,bl}$ = efficiency of the space heating back-up heater

In monoenergetic systems the back-up energy is generated by an electrical resistance heating, i.e. the efficiency of the back-up system is 100%.

3.4.3 B - Hot water mode

Domestic hot water systems are measured according to EN 255-3 [17]. The standard is described in more detail in chapter 4.4.1.4. One standard testing point is defined by EN 255-3. For air-to-water systems the testing point is A7, for brine-to-water systems the testing point is B0.

The relevant values for the calculation of the SPF of domestic hot water systems, which are delivered by EN 255-3, are the COP_t for the extraction of domestic hot water and the electricity input to cover storage losses P_{es}.

Step B1: Determination of operation points

As in the heating mode, the operation points shall be uniformly distributed over the whole operation range. The sink temperature is given by the required hot water temperature and assumed to be constant over the bin, thus the position of operation points can be chosen according to the source temperature. In combined operation it is best to choose the same operation points for heating and hot water operation.

Step B2: Determination of hot water requirements

The daily hot water power requirements can be calculated by eq. 33

$$Q_{DHW} = \rho_w \cdot \dot{V}_w \cdot c_w \cdot (\Theta_{hw} - \Theta_{cw})$$

eq. 33

where

Q_{DHW} = daily consumption of tapped domestic hot water [kJ/d]

ρ_w = density of water [kg/m³]

Ḃ_w = volumetric flow rate [m³/h]

c_w = specific heat capacity [kJ/(kg·K)]

Θ_{hw} = hot water temperature [°C]

Θ_{cw} = cold water temperature [°C]

The temperatures are input values. The hot water tapping volume can be taken from measurements or determined according to SIA 385/3 [29] depending on the use or the number of inhabitants of the building. SIA 380/1 [8] contains standard values for residential buildings as well. Given values of the tapping volume have to be recalculated from the nominal hot water temperature of e.g. 60°C to the corresponding bin hot water temperature by eq. 34

$$\dot{V}_{op} = \dot{V}_{ref} \cdot \frac{(\Theta_{ref} - \Theta_{cw})}{(\Theta_{op} - \Theta_{cw})}$$

eq. 34

where

Ḃ_{ref} = reference volumetric flow rate of tapped water at reference temperature, e.g. at 60°C

Ḃ_{op} = reference volumetric flow of tapped water at operation temperature

Θ_{cw} = cold water inlet temperature

Θ_{ref} = hot water reference temperature, e.g. 60°C

Θ_{op} = tapped hot water operation temperature

After this calculation the hot water extraction profile can to be taken into account. Standardized profiles for Switzerland are given in the VSSH handbook [30]. Number of heat generator operation hours in the respective bin is given by the bin, so DHW energy requirement can be calculated by eq. 35

$$Q_{DHW,i} = \rho_w \cdot \dot{V}_w \cdot c_w \cdot (\Theta_{hw} - \Theta_{cw}) \cdot t_i$$

eq. 35

where

$Q_{DHW,i}$ = domestic hot water energy in the bin

ρ_w = density of water

\dot{V}_w = volumetric flow rate

c_w = specific heat capacity of water

Θ_{hw} = hot water temperature

Θ_{cw} = cold water temperature

t_i = time in bin

Step B3: Correction of the standard COP_t-values

The COP_t values according to EN 255-3 [17] are evaluated by energy amounts. Thus losses due to cyclic operation are already included in the COP_t value and do not have to be corrected.

To correct the temperature effects on the COP only the source temperature has to be considered, since the average temperature differences for the storage loading are defined by the control system and do not change during the whole operation range. As only one standard testing point is defined in EN 255-3, correction cannot be done by interpolation. Presuming the source temperature does not deviate much from that of the testing point, a COP correction with fixed exergetic efficiency is a good approach. Details are described in chapter 4.4.2.2.

Step B4: Determination of system heat losses

Storage losses are not included in the COP_t-values according to EN 255-3, as the measured COP in phase 2 is corrected with the stand-by losses of the storage in phase 4, see chapter 4.4.1.4. However, EN 255-3 delivers the electricity power input that is necessary to cover the storage losses. Thereby storage losses of built-in storages can be taken into account.

Step B5: Determination of the running time of the heat pump

EN 255-3 does not deliver an output capacity. However, from the measurements an output capacity can be calculated according to [7]. This is described in more detail in chapter 4.6 of the test procedure for simultaneous operation. For the evaluation of the output capacity depending on the source temperature the heating characteristic measured according to EN 255-2 can be used temperature correction of the output capacity is done by linear interpolation or extrapolation according to eq. 36

$$\phi_{EN255-3}(\Theta) = \frac{\phi_{EN255-2}(\Theta_{upper}) - \phi_{EN255-2}(\Theta_{lower})}{\Theta_{upper} - \Theta_{lower}} \cdot (\Theta - \Theta_{lower}) + \phi_{EN255-3}(\Theta_{standard})$$

eq. 36

where

$\phi_{EN 255-3}(\Theta)$ = output capacity acc. to modification of EN 255-3 at arbitrary temperature

$\phi_{EN 255-3}(\Theta_{standard})$ = output capacity acc. to modification of EN 255-3 at temperature of testing point

$\phi_{EN 255-2}(\Theta_{upper})$ = output capacity acc. to EN 255-2 at temperature of upper testing point

$\phi_{EN 255-2}(\Theta_{lower})$ = output capacity acc. to EN 255-2 at temperature of lower testing point

With these modifications of EN 255-3 running time of the heat pump thus can be calculated by eq. 16. However, running time is related to produced energy, i.e. the used energy of the hot water and the energy produced to cover system losses, in particular the storage losses. If the (U·A)-value of the attached storage is known, storage losses can be calculated according to eq. 15. However, in the case of built-in storages, often no information is available. EN 255-3 delivers the electricity input, but not the thermal losses, since the COP of the storage loading is not known. A possibility to calculate the thermal storage losses from the electricity input is to calculate a COP-value for the storage loading with the approach of the exergetic efficiency described in chapter 4.4.2.2, i.e. a correction of the COP_t for the relevant temperatures of the storage loading. These temperatures are normally known or can be assumed: The outlet temperature can be set to the hot water extraction temperature, delivered by EN 255-3, and for the inlet temperature a value is available from the control system.

Step B6: Determination of auxiliary energy

With the running time of the system the auxiliary energy input can be calculated according to eq. 17. Since the electrical expense for the storage loading pump is already included in the COP_t according to EN 255-3, only the source pump has to be considered. As in the case of EN 255-2 parts of the auxiliary energy are already included in the COP_t , namely the power to overcome the internal pressure drop, thus only the external power has to be taken into account. The power reduction for the internal pressure drop can be calculated according to eq. 18 and eq. 19.

Step B7: Calculation of the bin performance factor

The bin performance factor for domestic hot water systems can be calculated according to eq. 37

$$PF_i = \frac{Q_{DHW, hp, i}}{\frac{Q_{DHW, hp, i}}{COP_t} + W_{aux} + P_{es} \cdot t_i}$$

eq. 37

where

PF_i = performance factor of bin i

COP_t = COP value for the extraction of domestic hot water according to EN 255-3, electric energy to cover storage losses is not included

$Q_{DHW, hp, i}$ = domestic hot water energy requirement covered by the heat pump in bin i

W_{aux} = auxiliary energy input in bin i

P_{es} = electrical power input to cover storage losses according to EN 255-3

t_i = time in bin i

Step B8: Weighting of the bin performance factor to the SPF domestic hot water

The seasonal performance factor can be calculated according to eq. 21. In the case of the domestic hot water system the weighting factors are defined according to eq. 38

$$w_i = \frac{Q_{DHW, hp, i}}{Q_{DHW, hp}}$$

eq. 38

where

$Q_{DHW, hp, i}$ = domestic hot water energy demand in bin i, delivered by the heat pump

$Q_{DHW, hp}$ = annual domestic hot water energy demand, delivered by the heat pump

Step B9: Weighting of the SPF_{DHW} of the heat pump water heater with back-up energy

In case of an installed back-up resistance heating, the SPF_{DHW} has to be weighted with the back-up energy to receive the system seasonal performance factor of the heat pump water heater. The amount of back-up energy is often determined by a temperature limit up to which the heat pump delivers the energy, e.g. 55°C, and above this limit, the missing energy is supplied by the back-up system. The energy fraction of the heat pump can thus be calculated according to

$$\delta_{hp, DHW} = \frac{Q_{DHW, hp}}{Q_{DHW}} = \frac{\rho_w \cdot \dot{V}_w \cdot c_w \cdot (\Theta_{upper, hp} - \Theta_{cw}) \cdot t_t}{Q_{DHW}}$$

eq. 39

where

$Q_{DHW, hp}$ = domestic hot water energy delivered by the heat pump

Q_{DHW} = domestic hot water energy requirement

ρ_w = density of water

\dot{V}_w = volumetric flow rate

c_w = specific heat capacity

$\Theta_{upper, hp}$ = upper temperature limit for the operation of the heat pump

Θ_{cw} = cold water inlet temperature to domestic hot water storage

t_t = total considered time period

The weighting with back-up energy is done according to eq. 40

$$SPF_{sys, DHW} = \frac{Q_{DHW}}{\frac{\delta_{hp, DHW} Q_{DHW}}{SPF_{hp, DHW}} + \frac{(1 - \delta_{hp, DHW}) Q_{DHW}}{\eta_{bu, DHW}}}$$

eq. 40

where

Q_{DHW} = total domestic hot water energy requirement

$\delta_{hp, DHW}$ = fraction of DHW energy demand covered by back-up heater

$\eta_{bu, DHW}$ = efficiency of the DHW heating back-up heater

As often no values of testing according to EN 255-3 are available, an approach to use the characteristic according to measurement of EN 255-2 is described in the following. The steps

only refer to the calculation of the single DHW operation based on EN 255-2, as the calculation of the single heating operation is the same as in mode A.

The basic difference between the calculation of the heating system and the domestic hot water systems according to EN 255-2 is, that the sink temperature during the loading of the storage does not stay constant, i.e. the COP during the loading changes according to the sink temperature. Thus an adequate average temperature for the loading has to be evaluated, which stays nearly constant for all bins, if the cold water temperature does not change too much over the year. If the inlet and outlet temperature at the end of the loading is known, an average temperature can be determined. With this average sink temperature a COP for the hot water extraction can be calculated. For the standby losses, another COP has to be calculated, as the inlet temperature normally will be higher in case of covering the storage losses, thus the COP will be lower because of the higher temperature levels right from the beginning of the heat pump operation. Note that these COP values do not correspond to the COP_t value, as the system boundary according to EN 255-2 and EN 255-3 is different. (See details on EN 255 in chapter 4.4.1). For the storage losses the (U·A) approach has to be applied. The rest of the calculation method is equivalent to the calculation of mode A.

3.4.4 AB - Alternate operation mode

For alternate operation mode of combined heating and hot water production with the same heat pump the heat pump is switched from single heating operation mode to single domestic hot water operation mode, so at every time the heat pump is in one single operation mode. There is no real combined operation, where heating and domestic hot water heat production takes place at the same time. Consequently the SPF-values for space heating and domestic hot water can be calculated according to the above calculation method A for single heating operation and B for single DHW operation. To evaluate the total seasonal performance factor of the alternate operation, these two SPF-values have to be weighted with the respective energy fraction for heating and domestic hot water requirements according to eq. 41

$$SPF_{sys} = \frac{Q_{bl} + Q_{DHW}}{\frac{Q_{bl}}{SPF_{sys,h}} + \frac{Q_{DHW}}{SPF_{sys,DHW}}}$$

eq. 41

where

SPF_{sys} = system seasonal performance of combined heating and DHW production

Q_{bl} = building energy demand for space heating

Q_{DHW} = domestic hot water energy demand

$SPF_{sys,h}$ = system seasonal performance factor for bivalent heating mode

$SPF_{sys,DHW}$ = system seasonal performance factor for bivalent domestic hot water mode

3.4.5 C - Simultaneous operation mode

As output capacity and COP characteristics of the simultaneous operation differ significantly from the other operation modes (single heating operation (winter time, DHW storage entirely loaded), single domestic hot water operation (summer operation, no heating)), more testing points have to be available to characterise the simultaneous operation. The development of adequate test procedures and suited calculation methods for different types of simultaneous operating heat pumps are to be developed in the IEA HPP Annex 28 [31]. One of the Swiss contributions for this IEA Annex 28 is an adequate test procedure for systems with condensate subcooling. It has been developed at WPZ Töss [7]. A summary of the test procedure is given in chapter 4.6.

Step C1: calculation of storage losses

Storage losses are calculated according to eq. 15 in case of a given (U·A)-value. In case of measurements according to EN 255-3, the approach described in step B5 using the exergetic efficiency can be applied.

Step C2: Determination of the energies produced in simultaneous operation

To calculate the seasonal performance factor of a simultaneous working heat pump the above method has to be extended to at least one more SPF-value characterising the simultaneous space heating and domestic hot water operation mode. An upper limit of the SPF_{combi} would be the maximum possible hot water production in combined operation, the lower limit a rather alternate operation.

The maximum possible hot water production in simultaneous operation is characterised by the load and thereby the running time of the heating and the domestic hot water part. The running time for heating or hot water respectively is calculated according to eq. 16. A domestic hot water output capacity, which is not delivered by the standard EN 255-3, is delivered by the test procedure of WPZ Töss [7] described in chapter 4.6. The output capacity for the simultaneous operation has to be applied for the evaluation of the fraction of simultaneous operation, as it is bigger than the output capacity for single operation, so that the running time of the heat pump is reduced and there is less simultaneous operation. Thus it is the adequate output capacity to estimate the maximum possible simultaneous operation, as the combined operation is not overestimated.

It is defined as following:

- if running time of the heating $t_{op,h}$ exceeds the running time of the domestic hot water $t_{op,DHW,i}$, i.e. $t_{op,h} > t_{op,DHW,i}$, the running time can be estimated with the entire running time of the hot water system, hence the running time in simultaneous operation is defined by eq. 42

$$t_{op,combi,max,i} = t_{op,DHW,i}$$

eq. 42

where

$t_{op,combi,max,i}$ = maximum running time in simultaneous operation in bin i

$t_{op,DHW,i}$ = total running time of the hot water system in bin i

The running time of the heating and the domestic hot water systems, respectively is calculated according to eq. 16.

- if the running time of the domestic hot water exceeds the running time of the heating i.e. $t_{op,h,i} < t_{op,DHW,i}$, simultaneous operation is limited by the maximum running time of the heating system

$$t_{op,combi,max,i} = t_{op,h,i}$$

eq. 43

where

$t_{op,combi,max,i}$ = maximum running time in simultaneous operation in bin i

$t_{op,h,i}$ = operation time of the heating system in bin i

Note that for the evaluation of the running time, the produced energy is relevant, i.e. the used energy plus the storage losses.

However the maximum possible simultaneous operation will not be realised, because domestic hot water energy and heating energy is not needed always at the same time. Moreover control has an influence on the simultaneous operation, e.g. storage loading determined by the two-point hysteresis controller. Therefore a factor for simultaneous

operation f_{combi} is introduced to take into account the shift in the respective energy demands. Preliminary remarks on the factor f_{combi} are given in chapter 4.7.

The respective running time in single and simultaneous operation can thus be calculated according to the following equations:

Running time in simultaneous operation

$$t_{\text{op,combi},i} = f_{\text{combi},i} \cdot t_{\text{op,combi,max},i} \quad \text{eq. 44}$$

where

$t_{\text{op,combi},i}$ = running time in simultaneous mode

$t_{\text{op,combi,max},i}$ = maximum possible running time in combined mode

$f_{\text{combi},i}$ = factor for simultaneous operation

With the running time in combined operation the produced energy of the heat pump can be calculated according to eq. 45

$$Q_{\text{DHW,prod,combi},i} = \phi_{\text{DHW,combi},i} \cdot t_{\text{op,combi},i} \quad \text{eq. 45}$$

where

$Q_{\text{DHW,prod,combi},i}$ = produced DHW energy by the heat pump in simultaneous operation mode

$\phi_{\text{DHW,prod,combi},i}$ = output capacity of the heat pump in simultaneous operation mode

$t_{\text{op,combi},i}$ = running time in simultaneous operation in bin i

The produced energy in single DHW operation mode can be calculated with eq. 46

$$Q_{\text{DHW,prod,sin},i} = Q_{\text{DHW,prod},i} - Q_{\text{DHW,prod,combi},i} \quad \text{eq. 46}$$

where

$Q_{\text{DHW,prod,sin},i}$ = produced heat energy by the heat pump in single operation mode

$Q_{\text{DHW,prod,combi},i}$ = produced heat energy by the heat pump in combined operation mode

$Q_{\text{DHW,prod},i}$ = energy production to cover the DHW requirement to be generated by the heat pump (used energy and storage losses)

The same equations can be applied for the heating system.

With these values, the running time in single operation for the heating system can be calculated according to eq. 47

$$t_{\text{op,DHW,sin},i} = \frac{Q_{\text{DHW,prod,sin},i}}{\phi_{\text{DHW,sin},i}} \quad \text{eq. 47}$$

where

$t_{\text{op,DHW,sin},i}$ = running time of the heat pump in single DHW operation mode

$Q_{\text{DHW,prod,sin},i}$ = produced heat energy by the heat pump in single DHW operation mode

$\phi_{\text{DHW,sin},i}$ = output capacity of the heat pump single DHW operation mode

The same equation can be applied for the heating system.

By the produced energies the fraction of simultaneous operation for the respective bin can be determined by eq. 48

$$\delta_{DHW,combi,i} = \frac{Q_{DHW,prod,combi,i}}{Q_{DHW,prod,i}}$$

eq. 48

where

$\delta_{DHW,combi,i}$ = fraction of simultaneous operation of the heating system in bin i

$Q_{DHW,prod,combi,i}$ = produced energy for DHW in simultaneous operation in bin i

$Q_{DHW,prod,i}$ = energy production to cover the DHW requirement to be generated by the heat pump (used energy and storage losses)

The same equation can be applied for the heating system

Step C3: determination of the weighting factors for simultaneous operation

The weighting factors are related to the used energy, i.e. the energy demand of the building or the hot water system respectively. Thus the used energy has to be calculated according to eq. 49

$$Q_{DHW,combi,i} = Q_{DHW,prod,combi,i} - Q_{I,s,DHW,combi,i}$$

eq. 49

where

$Q_{DHW,combi,i}$ = DHW energy requirement in the respective bin i covered by simultaneous operation

$Q_{DHW,prod,combi,i}$ = produced energy of the heat pump in DHW simultaneous operation

$Q_{I,s,DHW,combi,i}$ = DHW storage losses in simultaneous operation in bin i

The total storage losses are redistributed to the single and combined operation of the heating and domestic hot water operation respectively by the fraction of the respective combined operation calculated in eq. 48, e.g. for the DHW system in combined operation according to the equation

$$Q_{I,s,DHW,combi,i} = Q_{I,s,i} \cdot \delta_{DHW,combi,i}$$

eq. 50

where

$Q_{I,s,DHW,combi,i}$ = storage losses in combined operation in bin i

$Q_{I,s,i}$ = total storage losses in bin i

$\delta_{DHW,combi,i}$ = fraction of simultaneous operation of the DHW system

The weighting factor of the domestic hot water for the simultaneous operation corresponds to the energetic fraction of the used energy generated in simultaneous mode and can be calculated by eq. 51

$$w_{DHW,combi,i} = \frac{Q_{DHW,combi,i}}{Q_{DHW,combi}}$$

eq. 51

where

$w_{DHW,combi,i}$ = weighting factor for simultaneous operation in bin i

$Q_{DHW,combi,i}$ = DHW energy demand in the respective bin i covered by simultaneous operation

$Q_{DHW,combi}$ = total DHW energy produced in simultaneous operation

The weighting factor for the single operation is consequently described by

$$w_{DHW,sin,i} = \frac{Q_{DHW,sin,i}}{Q_{DHW,sin}}$$

eq. 52

where

$w_{DHW,sin,i}$ = weighting factor for single DHW operation in bin i

$Q_{DHW,combi,i}$ = DHW energy demand in the respective bin i covered by single operation

$Q_{DHW,combi}$ = DHW energy demand in single operation

The same equation can be applied for the heating system

Step C4: calculation of auxiliary energies

Auxiliary energies for the source and storage pumps are associated with the operation of the heat pump. Thus the running time of the heat pump has to be evaluated for the single and simultaneous operation to receive the respective fractions of additional auxiliary energies. The auxiliary energies for the single and simultaneous mode can be calculated both for the heating and the DHW system according to eq. 18. For the heating system the circulation pump, which is associated with the bin time, has to be taken into account, as well.

Step C5: calculation of bin performance factor

The calculation of the bin performance factor is performed in the same way as in mode A of the single operation heating according to eq. 20 and in mode B of the single operation DHW according to eq. 37. The weighting is performed according to eq. 21 with the weighting factors calculated in step C3 (eq. 51). Results are the seasonal performance factors for the combined operation, $SPF_{h,combi}$ and $SPF_{DHW,combi}$.

The seasonal performance factor for single domestic hot water operation is not the same as in alternate operation, as the weighting factors are changing, so the $SPF_{h,sin}$ and $SPF_{DHW,sin}$ have to be calculated according to mode A and mode B respectively, as well.

Step C6: calculation of the respective seasonal performance factors for heating and DHW

The system performance factors for heating and DHW operation is done by energetic weighting according to eq. 53 for space heating

$$SPF_h = \frac{Q_{h,sin} + Q_{h,combi}}{\frac{Q_{h,sin}}{SPF_{h,sin}} + \frac{Q_{h,combi}}{SPF_{h,combi}}}$$

eq. 53

where

SPF_h = seasonal performance factor for the heating operation

$SPF_{h,sin}$ = seasonal performance factor heating for single operation in combined operation mode

$SPF_{h,combi}$ = seasonal performance factor for the combined heating operation

$Q_{h,sin}$ = used heat energy produced in single operation

$Q_{h,combi}$ = used heat energy produced in combined operation

The same equation can be applied to the domestic hot water operation

Step C7: calculation of overall seasonal performance factor for simultaneous operation

The total SPF for a monovalent system is calculated according to

$$SPF_{hp} = \frac{Q_{h,sin} + Q_{h,combi} + Q_{DHW,sin} + Q_{DHW,combi}}{\frac{Q_{h,sin}}{SPF_{h,sin}} + \frac{Q_{h,combi}}{SPF_{h,combi}} + \frac{Q_{DHW,sin}}{SPF_{DHW,sin}} + \frac{Q_{DHW,combi}}{SPF_{DHW,combi}}}$$

eq. 54

where

SPF_{hp} = seasonal performance factor for the heat pump operation

$SPF_{h,sin}$ = seasonal performance factor heating for single operation in combined operation mode

$SPF_{h,combi}$ = seasonal performance factor for the combined heating operation

$SPF_{DHW,sin}$ = seasonal performance factor heating for single operation in combined operation mode

$SPF_{DHW,combi}$ = seasonal performance factor for the combined heating operation

$Q_{h,sin}$ = space heating energy requirement covered in single operation

$Q_{h,combi}$ = space heating energy requirement covered in combined operation

$Q_{DHW,sin}$ = DHW energy requirement covered in single operation

$Q_{DHW,combi}$ = DHW energy requirement covered in simultaneous operation

$Q_{DHW,combi}$ = domestic hot water energy requirement covered by combined mode operation

For bivalent systems, the corresponding system seasonal performance factors SPF_{sys} have to be put in.

Weighting with back-up energy is performed according to mode A eq. 22 to eq. 32 and mode B eq. 40.

4 DATA SOURCES FOR THE SINGLE CALCULATION STEPS

4.1 Meteorological Data

4.1.1 Preprocessing of the meteorological data

The basis for the evaluation of the heating requirement in different temperature bins are hourly values of the dry bulb ambient air temperature. Sources for these hourly values can be design reference years for the site, which are produced as average values of long-term measurements by meteorological stations or yearly measurements of the site. If these data are not available for the site, special software like METEONORM [10] can be used to produce the required input data. It contains monthly average values for sites all over the world and applies a statistical approach to calculate hourly values of the ambient temperature and other meteorological values.

The calculation method presumes that the heating requirement basically depends on the ambient temperature. This is not correct for modern buildings where the impact of solar gains and internal loads are much more important than in existing building and a principal dependency of the heating requirement on the outside temperature could be a quite rough approach. However, these building can be treated as well by a shift of the length of the heating period. Investigations documented in [1] show, that a higher fraction of internal and external gains influences the absolute energy production of the heat pump and the back-up heater, but does not change significantly the fractions of energy produced by the respective heat generator.

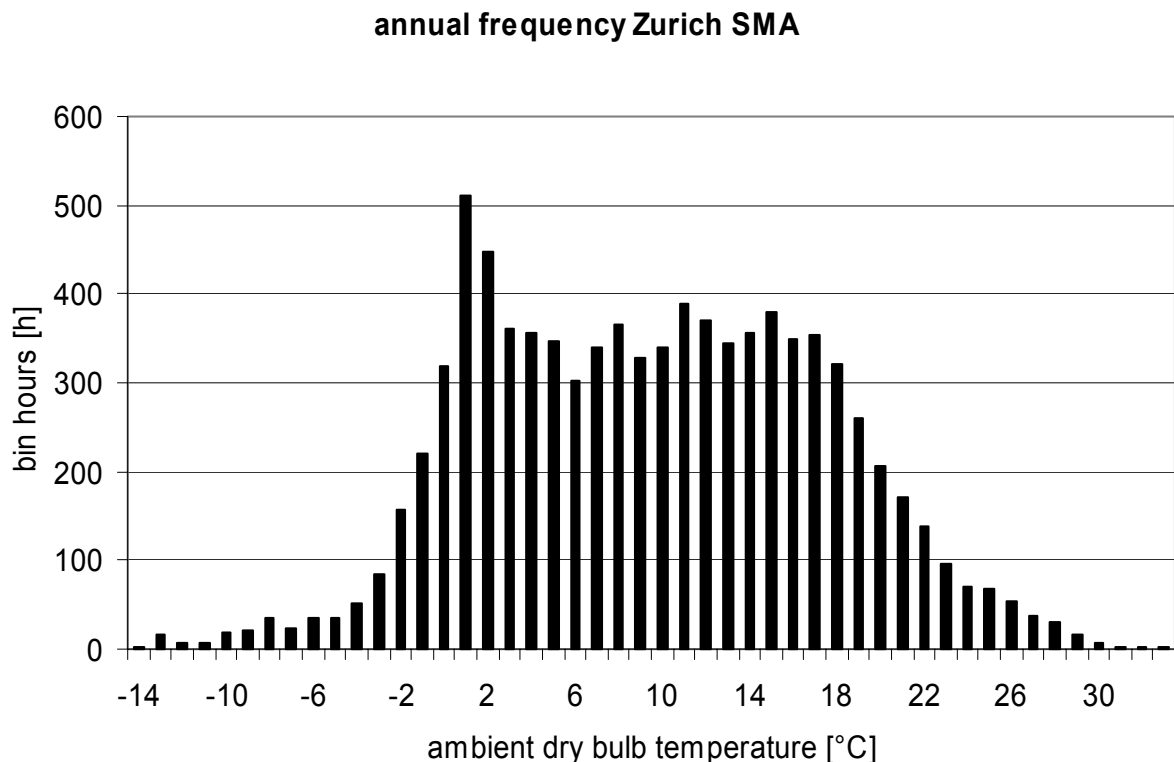

Fig. 8: annual frequency of the ambient dry bulb temperature

Moreover most of these modern buildings according to the Swiss MINERGIE-P standard or the German passive house standard use air distribution systems for heating and, if a heat pump is integrated in the generation part at all, in most cases exhaust air heat pump are used in unitary systems. Both an air distribution system and a source of exhaust air is not in the scope of this project, however will be part of a follow-up project.

As first step of the processing of the meteorological data of the site a classification of the ambient temperature to classes of 1 K, called bins, is carried out. The result is the annual frequency of the dry bulb temperature of the site. An example is given in Fig. 8. These bins can be cumulated to receive the cumulated annual frequency, which is shown in Fig. 9. The cumulative annual frequency can be used in the calculation method to evaluate the total time in the respective bin.

cumulative annual frequency Zurich SMA

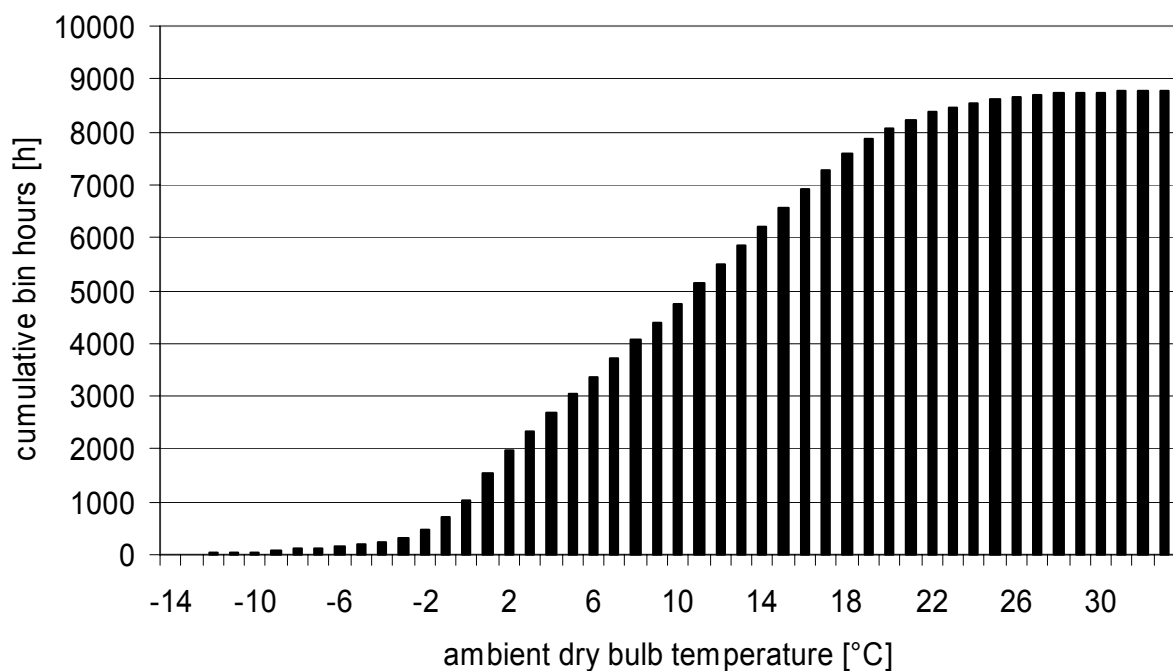

Fig. 9: cumulative annual frequency of the ambient dry bulb temperature

To represent the energy demand of the respective bin, the heating degree hours (HDH) are calculated in the next step by eq. 55

$$HDH_i = \sum_{i=1}^{\Theta_{\max,i}} (\Theta_{ID} - \Theta_{\text{amb}})$$

eq. 55

where

HDH_i = heating degree hours

Θ_{max,i} = upper temperature limit for heating

Θ_{ID} = indoor design temperature

Θ_{amb} = ambient dry bulb air temperature

i = bin number

With the heating degree hours the relation of the heating requirement of the respective bin and the total heating requirement is calculated by equation eq. 56

$$w_i = \frac{HDH_i}{HDH_t}$$

eq. 56

where

w_i = weighting factor

HDH_i = heating degree hours up to bin i

HDH_t = total heating degree hours (summed up to the upper temperature limit for heating)

With the weighting factor w_i the weighting of the operation condition in the respective bin to the seasonal performance is done. Fig. 10 shows the distribution of fractional bin hours evaluated for 1 K bins of the site Zurich – SMA.

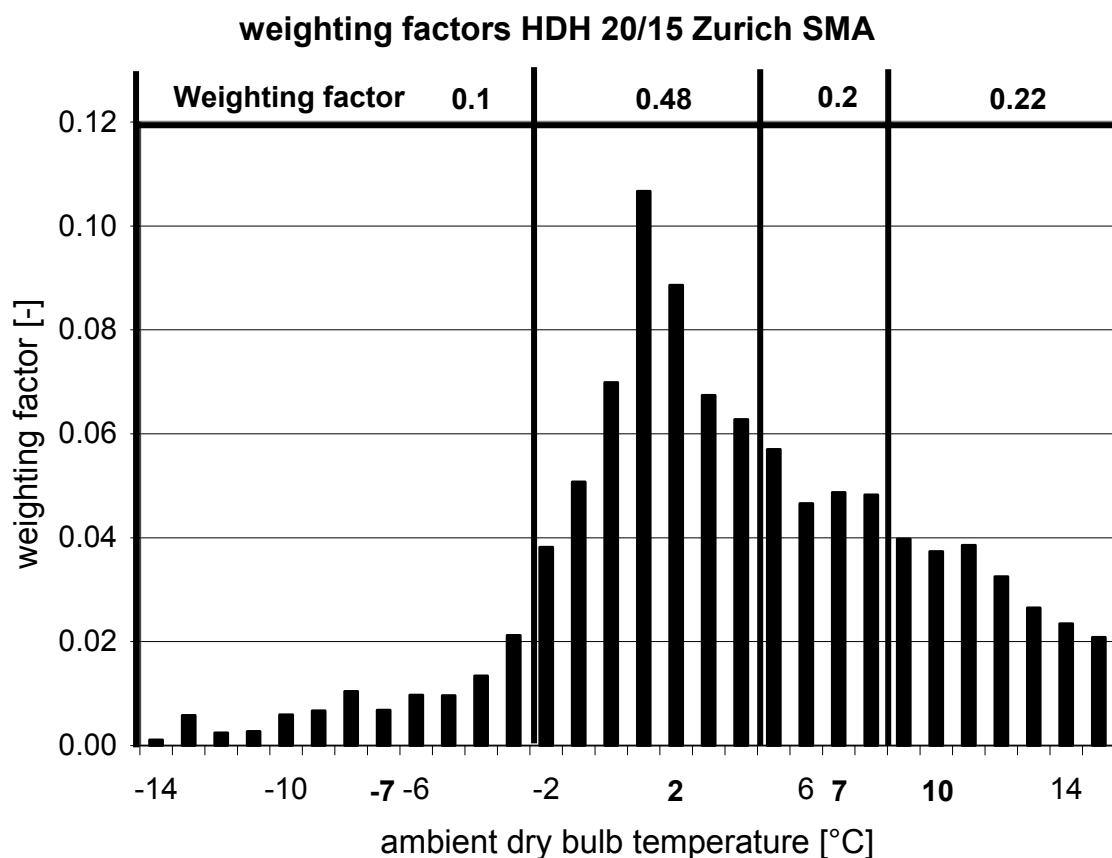

Fig. 10: weighting factors for 1 K temperature bins derived from meteorological data Zurich SMA

It can be concluded from Fig. 10 that for the meteorological conditions of the Swiss middleland the relevant temperature range is between -2 °C and +12°C. At the lower end of the temperature scale around the design outside temperature of the site, the temperature difference is high, but the frequency is very low. At the upper end of the temperature scale near the upper temperature limit for heating, the temperature difference to the design indoor temperature is low. By the meteorological data the contribution of a second generator to the total heating requirement in bivalent operation mode is evaluated, too, as described in chapter 3.4.2. The meteorological data are tabled in 1 K resolution, which corresponds to 1 K

temperature bins as shown in Fig. 10. In this way arbitrary size of the bins can be chosen, as the values simply have to be added, as far as they are not already cumulated, as shown in the top of Fig. 10.

To give an idea of the impact of the meteorological data on the weighting factors, Tab. 5 gives the weighting factors for three operation points at the testing points, where -7 corresponds to the interval $[\Theta_{OD}..-2]$, 2 corresponds to the interval $[-2..4]$ and 7 corresponds to interval $[4.. \Theta_{uh}]$. The corresponding data of different cities in Europe are generated on the basis of hourly values produced with METEONORM [10].

Tab. 5: comparison of the weighting factors for five European sites

City	Weighting factor -7°C	Weighting factor 2°C	Weighting factor 7°C
London	0.01	0.199	0.79
Oslo	0.31	0.385	0.305
Rome	0.0005	0.121	0.878
Zurich SMA	0.185	0.452	0.363
Moscow	0.59	0.205	0.205

From this table it can be concluded, that e.g. in Rome or London, the testing point at - 7°C is irrelevant, while in Oslo or Moscow, it would be very useful to have a testing point at - 15°C. This is a hint for the testing method, if a standard applicable for whole European climates is to be developed. There could be a definition of basic testing point, which are mandatory for all countries, and some optional testing points, which are required only in countries with the need for low temperature operation.

4.2 Source temperature

4.2.1 Air-to-water heat pumps

In the case of air-to-water heat pumps, the source temperature corresponds to the dry bulb ambient air temperature Θ_{amb} , which is already given by the meteorological data.

4.2.2 Brine-to-water heat pumps

The evaluation of the source temperature for brine to water heat pumps is more difficult, since the temperature depends significantly on the thermal characteristics of the ground and on the time in the heating season, as the ground is cooled down by the continuing extraction of heat.

Therefore, additional software has to be used to evaluate the ground temperature. Profiles for Switzerland can be generated with the software EWS [27], which delivers the supply temperature of the brine dependent on user defined boundary conditions. Two problems occur: on the one hand, there is an interdependence of the ground temperature and the heat pump demand, so the temperature profile generated is based on a certain heating profile and the heating profile is influenced by the heat demand of the heat pump. On the other hand, the brine temperature profile is time dependent, but to be applicable for the method, it has to be related to the ambient temperature, as the whole calculation is based on the evaluation of the ambient temperature bins.

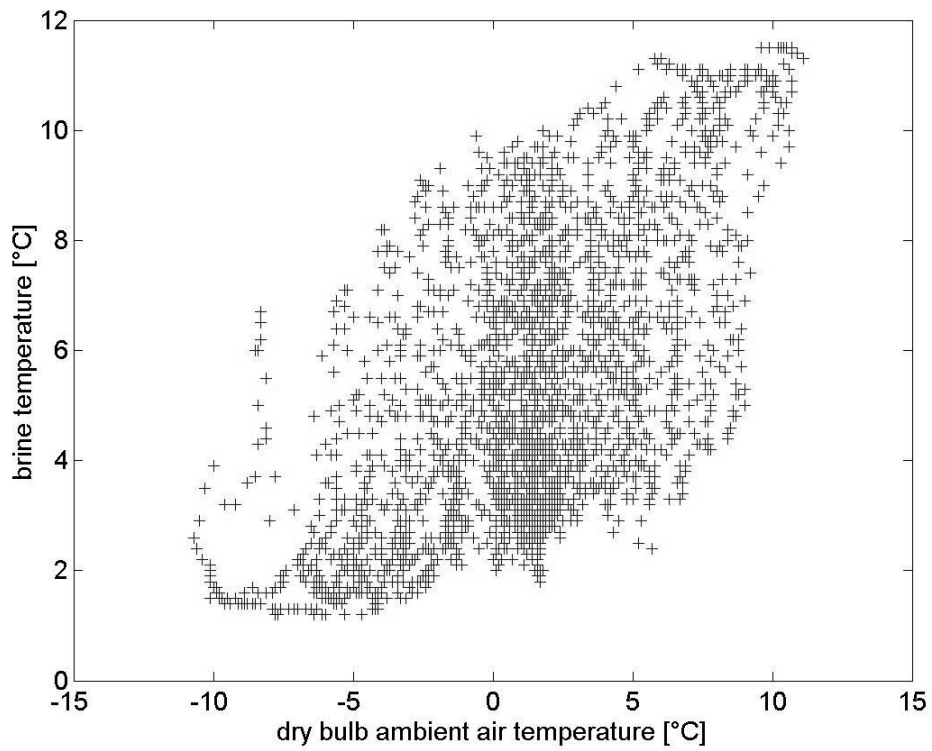

Fig. 11: brine source inlet temperature to the heat pump vs. ambient air temperature

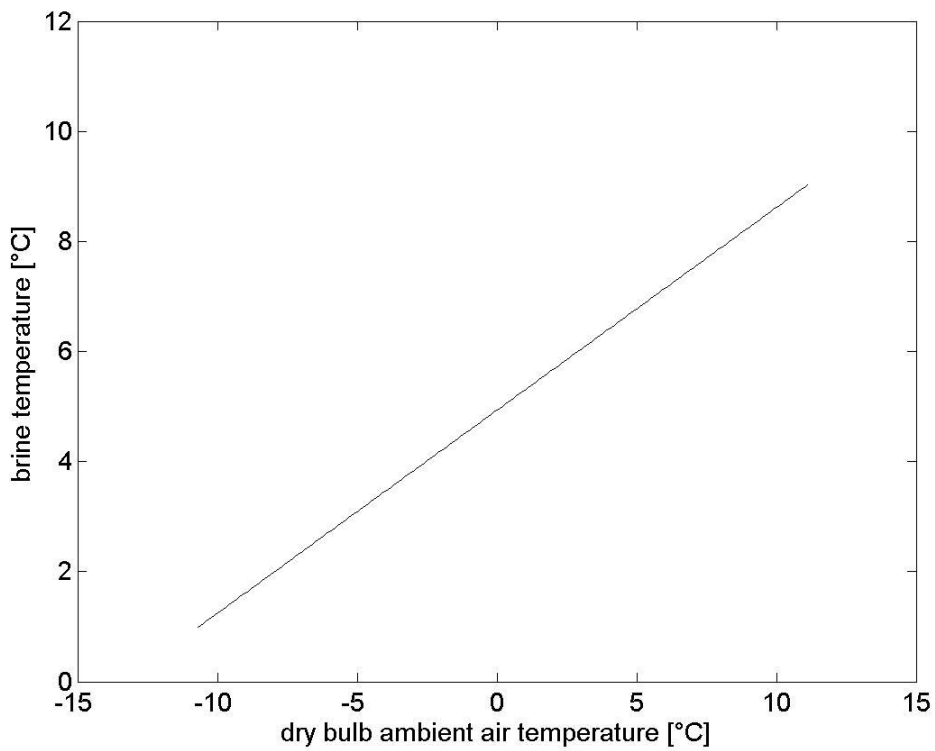

Fig. 12: regression of brine source inlet temperature to the heat pump vs. ambient air temperature

A first approach for the derivation of a profile is linear regression of the profile from measured data or profiles generated with EWS. Fig. 11 shows the single values of the brine temperature plotted vs. the ambient dry bulb air temperature, Fig. 12 the linear regression.

For a hand calculation method implemented in a standard a fixed profile has to be given to guarantee the same calculation for every heat pump. A profile based on measured data is given by Eugster [49], which is shown in Fig. 13.

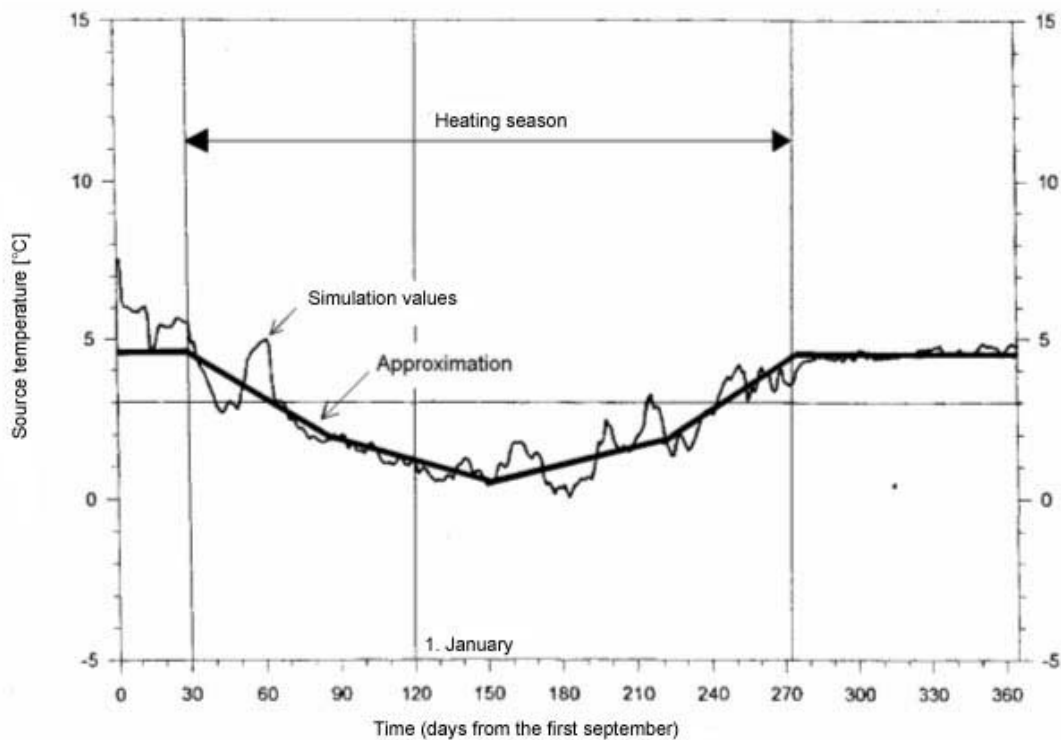

Fig. 13: profile of the brine inlet temperature of the heat pump for the heating period according to [49]

4.2.3 Water to water heat pumps

In the case of water-to-water heat pumps the source temperature is presumed constant over the year. Depending on the site the temperature of the ground water has to be determined and it can be applied in the same way as the brine temperature profile.

4.3 Heating and hot water demand

4.3.1 Energy requirement of the heating system

In Switzerland, the national standard for the calculation of the energy consumption of buildings is the SIA 380/1 [8], which is the national implementation of the European standard EN 832 [41]. The calculation method of SIA 380/1 performs a monthly energy balance of the building, which considers heat losses by transmission and ventilation, by heat bridges as well as internal and external gains. The required boundary conditions are given in the standard for different usage and types of the building.

As the calculation method of the seasonal performance factor of the heat pump system presented in chapter 3 is intended to deliver a value, which could be expected from the system, the calculated energy values according to SIA 380/1 seems to be better suited as the design heat load of the building according to SIA 384/2 [9], which is used as design value for the heat generation system and intend to meet the extreme meteorological conditions. Experience shows that the yearly energy values based on the design heat load according to SIA 384/2 deliver higher values. Therefore in American standardisation, a constant factor of 0.77 is introduced in the calculation method of ASHRAE 116 [6] to achieve better matching with measured values of the heating requirement. The energy in the respective bin is derived by the yearly energy value of the building delivered by SIA 380/1 multiplied by the respective weighting factor.

4.3.2 Energy requirement of the domestic hot water system

SIA 380/1 delivers values for the domestic hot water requirement, as well. For Switzerland, more detailed information on the hot water energy requirement dependent on the use of the building and/or dependent on the number of persons are given in the standard SIA 385/3 [29]. An extract is shown in Tab. 6.

Tab. 6: Hot water demand for residential buildings according to SIA 385/3

Unit	Type of Building	general function Hints	Hot water demand in liters à 60°C/day Averaged values per unit			
			Unit	1	2	3
	Housing and analog Buildings					
	Single-family houses	simple standard	P	30	35	40
	Condominiums	average standard	P	35	40	50
		elevated standard	P	40	50	60
	Multi-family houses	general house building	P	30	35	45
		elevated house building	P	35	40	50

where

- 1 – Minimum value that must not be fallen below in the design of DHW system
- 2 – Average values to be used for the calculation of annual seasonal energy requirement
- 3 – Peak demand to be used for the design of the DHW storage volume and heat generator

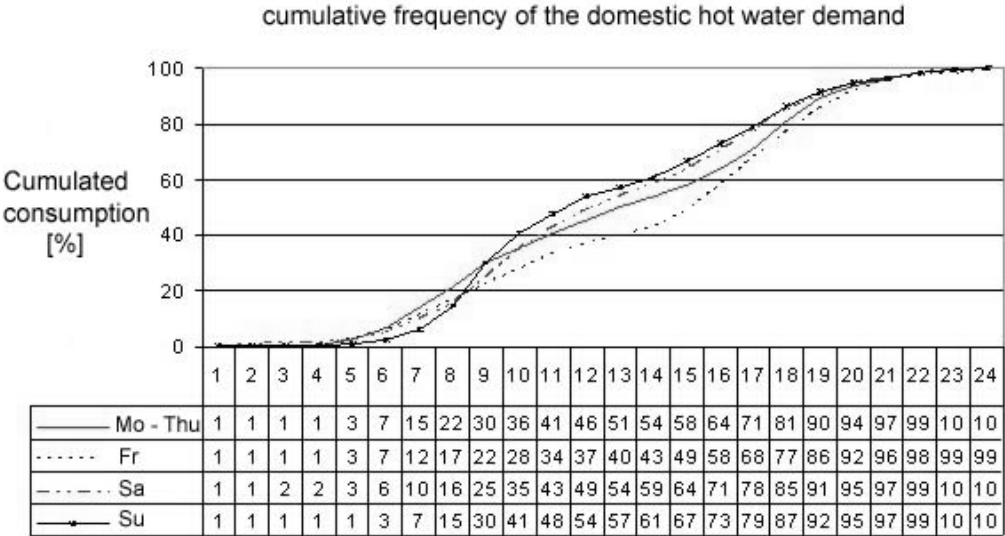

Fig. 14: tapping profile according to VSSH handbook

Information on tapping profile for Switzerland for different weekdays and the weekend are contained in the VSSH handbook [30], which is shown in Fig. 14.

On European level, standard tapping profiles have been published as European tapping cycles in a mandate to CEN for the elaboration and adoption of measurement standards for household appliances [53]. The mandate contains three tapping cycles, which are used for different hot water applications. Tab. 7 shows the tapping cycle Nr.1. The flow-rate is differentiated in kitchen type draw-offs versus other draw-offs. For the latter the specific flow rate (as given by the manufacturer) is applied. For the former the kitchen flow rate is applied as described in prEN 13203 [55], namely at 2/3 of the specific flow rate.

Tab. 7: European tapping cycle Nr. 1

EU reference tapping cycle nr. 1						
	<i>hr.min start</i>	<i>energy (kWh)</i>	<i>type</i>	<i>ΔT desired(K), to be achieved during tapping</i>	<i>min. ΔT (K), =start of counting useful energy</i>	<i>flow rate, S=specific rate, R= 2/3 * S</i>
1	07.00	0,105	small		15	S
2	07.30	0,105	small		15	S
3	08.30	0,105	small		15	S
4	09.30	0,105	small		15	S
5	11.30	0,105	small		15	S
6	11.45	0,105	small		15	S
7	12.45	0,315	dishwash	45	0	R
8	18.00	0,105	small		15	S
9	18.15	0,105	clean		30	R
10	20.30	0,420	dishwash	45	0	R
11	21.30	0,525	large		30	S
total		2,1				

equivalent hot water litres at 60°C

36

S= measurement at specific flow rate

R= measurement at a minimum of 2/3 of the specific flow rate

4.4 Values for COP and output capacity

The output capacity and the COP values characterise the power of the heat pump and have to be measured in standard test procedures. In the following chapter, different data sources and the influences on the calculation method are discussed.

4.4.1 Test procedures in European standardisation

4.4.1.1 EN 255-2

In Europe heat pumps for heating are tested according to EN 255-2 [16]. The standard testing points defined in EN 255-2 is listed in Tab. 8.

Tab. 8: Standard testing points according to EN 255-2:1997

Test conditions		(T1)	(T2)	(T3)	(T4)
Outside air/water	with defrost control	A7(6)/W50	A2(1,5)/W35	A15(12)/W50	A-7(-8)/W50*
	without defrost control	A7(6)/W50	A15(12)/W50	A7(6)/W35**)	
Exhaust air/water		A20(12)/W50	A20(12)/W35		
Water/water		W10/W50	W10/W35	W15/W50	
Brine/water		B0/W50	B0/W35	B5/W50	
Outside air/recycled air	with defrost control	A7(6)/A20(12)	A2(1,5)/A20(12)	A-7(-8)/A20(12)***)	
	without defrost control	A7(6)/A20(12)	A15(12)/A20(12)		
Exhaust air/recycled air		A20(12)/A20(12)			
Exhaust air/fresh air		A20(12)/A7(6)			
Outside water/recycled air		W10/A20(12)	W15/A20(12)		
Outside brine/recycled air		B0/A20(12)	B5/A20(12)		
Internal closed water loop/recycled air		W20/A20(12)			
NOTE 1: All air temperatures are inlet temperatures in °C. Water temperatures for indoor heat exchangers are outlet temperatures. Water and brine temperatures for outdoor heat exchangers are inlet temperatures.					
NOTE 2: All air temperatures in brackets are wet bulb temperatures in °C.					
NOTE 3: All tests are carried out with nominal flow rates indicated by the manufacturer, in m ³ /s. Where no flow rate is indicated and only a range of flow rates is given, testing shall be carried out at the minimum value.					
NOTE 4: The permissible external differential pressure at the evaporator and condenser shall be indicated by the manufacturer in Pa for appliances with duct connection and for those discharging air into double floor, double ceiling and double wall. If the fan is not included, the internal differential pressure shall be indicated instead.					
*) If not (T4), then A2(1,5)W50.					
**) If not (T3), then A10(8)W35.					
***) (T3) Only where possible.					

For air-to-water systems an interpolation on the basis of the testing point according to EN 255-2 is difficult, because there is little information about the defrosting area. The characteristic of 50°C hold only one value A7/W50 in the range of defrosting operation of the heat pump, and the point A2/W35 cannot be transferred easily to the 50 degree line. A suggested method by Feldmann [5], which uses the points (T1), (T2) and (T4) shows good accordance in the cases of some heat pumps, but does not deliver exact results for **all** heat pumps, as the bend in performance characteristic due to defrost losses is not always at the anticipated position. Moreover the distance between the 35°C and 50°C line is not always constant. Therefore the method cannot be used for a comparison of different heat pumps.

So in the case that only the measurements of EN 255-2 are available, either manufacturers' data have to be used to get information on the whole operation range – however, it should be secured, that the data are based on EN 255-2 measurements - or correction for temperatures may be carried out with the method of a exergetic efficiency discussed in 4.4.2.2.

4.4.1.2 EN 255-2 according to the Töss reglement

Testing at the Swiss national test centre WPZ in Winterthur-Töss is performed according to the Töss reglement [26] based on EN 255-2. Besides further extensions, e.g. operation limits, the testing points are extended to five points at two supply temperature levels in the case of air-to-water and to three points in the case of brine-to-water. Fig. 4 gives an overview of the testing points of WPZ Töss. Test results are published in a quarterly Bulletin, which can be downloaded from the Internet [11]. These data are well suited for an interpolation of the heat pump characteristics. A comparison of different interpolation method has been made and is shown in Fig. 16.

4.4.1.3 prEN 14511

The standard prEN 14511 is a new draft, which will replace the EN 255-2. prEN 14511 passed CEN enquiry with many comments thus it will probably be used in about 2 years. In prEN 14511 the new standard testing points according to Tab. 9 are defined

Tab. 9: standard testing points according to prEN 14511

		Outdoor heat exchanger		Indoor heat exchanger	
		Inlet dry bulb temperature °C	Inlet wet bulb temperature °C	Inlet temperature °C	Outlet temperature °C
Standard rating conditions	outdoor air	7	6	40	45
	exhaust air	20	12	40	45
	Outdoor air (for floor heating application)	7	6	30	35
	Exhaust air (for floor heating application)	20	12	30	35
Application rating conditions	Outdoor air (for floor heating application)	2	1	*	35
	Outdoor air (for floor heating application)	- 7	- 8	*	35
	Outdoor air (for floor heating application)	- 15	-	*	35
	outdoor air	2	1	*	45
	outdoor air	- 7	- 8	*	45
	outdoor air	- 15	-	*	45
	outdoor air	7	6	**	55
	outdoor air	-7	-8	**	55

* The test is performed at the water flow rate obtained during the test at the corresponding standard rating conditions.
 ** The test is performed at the water flow rate at the corresponding standard rating conditions with 40/45 °C at the indoor heat exchanger.

Actually, all testing points, i.e. standard and application rating are mandatory, so there are quite a lot of testing points available, if the standard will be realised in the actual state. The problems in interpolation are solved then, being caused by the little number testing points of EN 255-2.

4.4.1.4 EN 255-3

Domestic hot water heat pump systems are tested according to EN 255-3. Fig. 15 shows the testing cycle of EN 255-3. The curve shows the temperature of the water exiting the hot water storage. The testing cycle consists of 5 phases. The relevant phases for the determination of the COP-value, called COP_t in EN 255-3, are phase 2 and phase 4. The single phases are described shortly in the following.

Phase 1:

Starting in the thermal equilibrium with the environment of 20°C, the storage is heated up to the used hot water temperature a first time.

Phase 2:

Directly after the switching-off of the heat pump by the temperature controller half the storage is unloaded, and then, the storage is reheated again. This procedure is done several times until the energy content in the extracted amount of hot water does not vary more than 10 % to the one before. The last cycle is taken to calculate a preliminary COP value according to the eq. 57

$$COP_{\text{phase2}} = \frac{Q_t}{W_t}$$

eq. 57

where

COP_{phase2} = preliminary COP value evaluated from phase 2 measurements

Q_t = energy of the tapped hot water

W_t = electricity input to the heat pump

The phase 2 COP thus contains the storage losses.

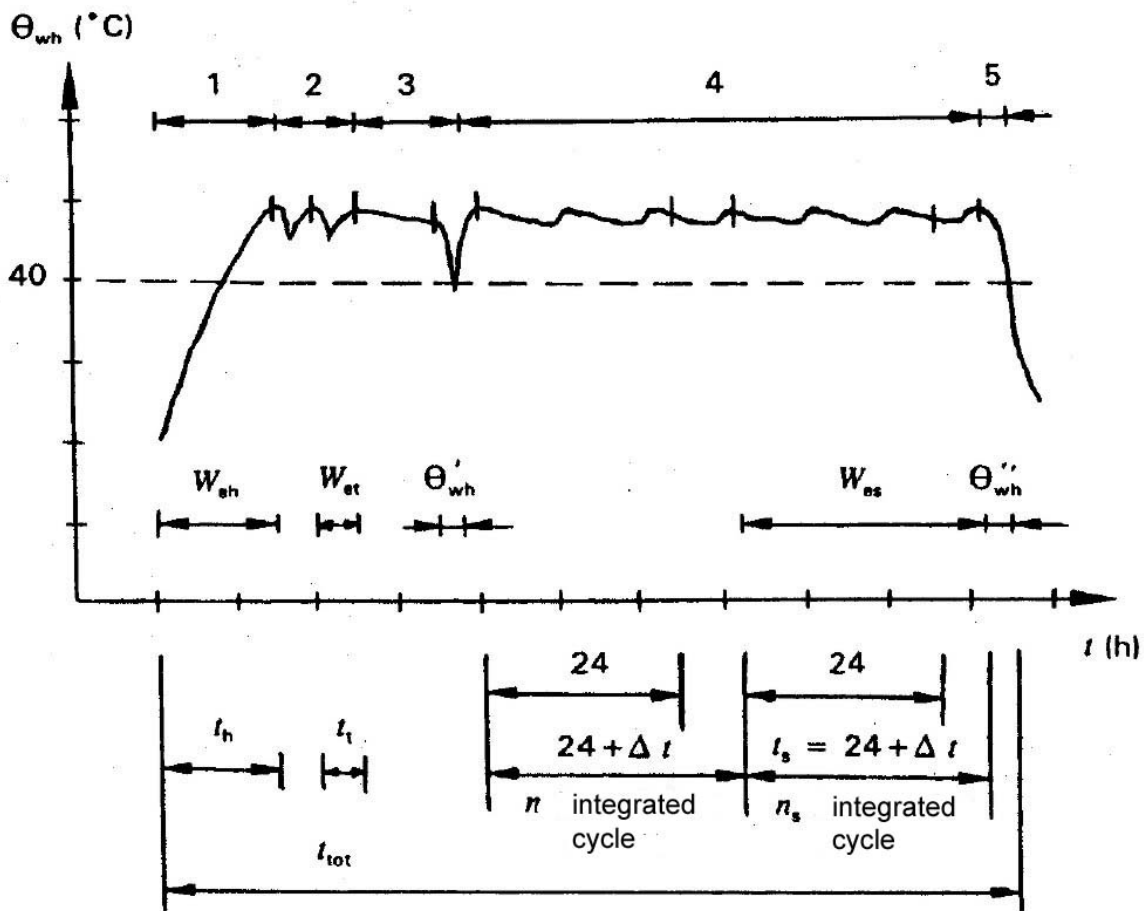

Fig. 15: Testing cycle according to EN 255-3 [17]

Phase 3:

The system is left until it is switched-on by the controller. After that a hot water tapping is initiated until a tap temperature of 40°C is reached. The values of phase 3 are used for capacity calculations of maximum useable water at hot water temperature

Phase 4:

The storage is loaded again and left in standby operation. The electrical energy input is recorded during this standby period. The energy input during phase 4 is used to calculate the stand-by expense P_{es} by the equation

$$P_{es} = \frac{W_{es}}{t_s}$$

eq. 58

where

P_{es} = electricity input to cover stand-by storage losses

W_{es} = electrical energy input during phase 4

t_s = time period of phase 4

This values P_{es} is used to correct the preliminary COP values of phase 2 for the storage stand-by losses to receive the COP_t -value according to the equation

$$COP_t = \frac{Q_t}{W_{et} - P_{es} \cdot t_t}$$

eq. 59

where

COP_t = COP value for the extraction of domestic hot water delivered by the EN 255-3

Q_t = thermal energy of the hot water draw-off during the last cycle of phase 2

W_{et} = electrical energy input during phase 2

t_t = time period of the evaluated cycle of phase 2

Phase 5 comprises another draw – off to 40°C, which is used for capacity calculations.

Thus the COP_t value does not include the storage losses any more, as they are explicitly recalculated and can thus be applied to any system configuration. The method is very effective for systems with integrated hot water storages, when no information on the losses of the storage are provided.

However, the test procedure is more time-expensive as testing according to EN 255-2, as a full test cycle takes about 4 days to deliver one point of the heat pump characteristic. To receive the heat pump characteristic over the whole operation range by interpolation (relevant for changing source and sink temperatures), more tests should be performed.

In the case of external hot water storage, the storage losses can be calculated based on manufacturer's data according to eq. 15. With this possibility testing points of the heating characteristic can be corrected for the storage losses, and thereby the use of expensive testing according to EN 255-3 can be reduced. However, in the parallel project at WPZ Töss [7], it has been experienced, that storage losses depend on the operation point. Moreover heat pump characteristic changes with the draw-off profile, so more than one standardized profiles should be used.

4.4.1.5 Conclusions of the overview with regard to the calculation method

EN 255 is well suited to deliver the required component specific input data for the calculation method. With the experience during the development of a test procedure for the combined operation described in [7] and with regard to the calculation method presented in chapter 3 for combined operation, some small modifications and additions in EN 255 seem sensible, since they do not change the standard test procedure much, but deliver values, which facilitate the calculation in particular in the case of combined operating systems. They are listed in chapter 4.6.1

4.4.2 Methods for temperature correction of standard COP and output capacity

4.4.2.1 Polynomial fitting with quartic polynomials

The heat pump is assumed to act like a „black box“, with the dry-bulb temperature Θ_{amb} and the condenser inlet temperature $\Theta_{con,in}$ as input, and the condenser outlet temperature $\Theta_{con,out}$, the heating capacity, ϕ_{hp} the power consumption P_{hp} and COP as output with polynomials of the form

$$\phi_{hp} \text{ [or } P_{hp}] = a_0 + a_1 \cdot \Theta_{amb}^* + a_2 \cdot \Theta_{con,out}^* + a_3 \cdot \Theta_{amb} \cdot \Theta_{con,out}^* + a_4 \cdot \Theta_{amb}^2 + a_5 \cdot \Theta_{con,out}^2$$

eq. 60

where Θ is normalized as

$$\Theta^* = \frac{\Theta}{1 + 273.15}$$

eq. 61

The heat pump's steady-state performance can be calculated. An iteration has to be carried out, because the polynomials are dependent on Θ_{amb} and $\Theta_{con,out}$, the „black box model“, however on Θ_{amb} and $\Theta_{con,in}$. In case of air-to-water heat pumps frost/defrost losses are already included in the manufacturer data and thereby considered.

4.4.2.2 Correction with CARNOT factor (exergetic efficiency)

This method is applied by the calculation method of HTA Lucerne in the SFOE project “low-cost low-temperature heating with heat pump” [4]. The idea of the method is that the thermodynamic quality of the process stays constant over the whole operation range. Thermodynamic quality of a process can be expressed by the exergetic efficiency as ratio between the real COP of the process and the ideal COP of the Carnot process. The exergetic efficiency can thus be calculated by eq. 62.

$$\eta_{ex} = \frac{COP}{COP_C}$$

eq. 62

where

COP = coefficient of performance

COP_C = Carnot COP

The CARNOT efficiency is calculated according to the equation

$$COP_C = \frac{T_{hot}}{T_{hot} - T_{cold}} = \frac{\Theta_{si} + 273.15}{\Theta_{si} - \Theta_{so}}$$

eq. 63

where

COP_C = Carnot COP

T_{hot} = temperature at the hot process side
 T_{cold} = temperature at the cold process side
 Θ_{si} = sink temperature
 Θ_{so} = source temperature

Both source and sink temperature can be corrected with this approach. The advantage of the method is that only one testing point is needed. In case of testing according to EN 255-3, where only one testing point is defined, an interpolation to correct the COP values for changes of the source temperature is not possible, but a correction with the exergetic efficiency is still applicable.

Then an effective COP at varying source temperatures can be calculated according to the eq. 64

$$COP_{eff} = COP_{standard} \cdot \frac{COP_{C,eff}}{COP_{C,standard}}$$

eq. 64

where

COP_{eff} = COP at changing source temperatures

$COP_{standard}$ = COP at measured standard testing point according to EN 255

$COP_{C,eff}$ = CARNOT COP at changing source temperatures

$COP_{C,standard}$ = CARNOT COP at measured standard testing point according to EN 255

If the sink temperature varies during the considered time span, e.g. in case of a storage loading after a hot water tapping or to cover standby losses, according to [7] the Carnot efficiency has to be integrated over the temperature range, i.e. the Carnot efficiency is calculated according to the equation

$$COP_C = \frac{\int_{\Theta_{cw}}^{\Theta_{hw}} \frac{\Theta_{si} + 273.15}{\Theta_{si} - \Theta_{so}} d\Theta_{si}}{(\Theta_{hw} - \Theta_{cw})}$$

eq. 65

where

COP_C = Carnot COP

Θ_{in} = inlet temperature of the cold water

Θ_{hw} = used temperature of the hot water during phase 2 of EN 255-3

Θ_{si} = sink temperature of the heat pump

Θ_{so} = source temperature of the heat pump

The integral can be solved analytically, so that the equation can be written in the form

$$COP_C = 1 + \frac{(\Theta_{so} + 273.15)}{(\Theta_{hw} - \Theta_{cw})} \cdot \ln\left(\frac{\Theta_{hw} - \Theta_{so}}{\Theta_{cw} - \Theta_{so}}\right)$$

eq. 66

where

COP_C = Carnot COP

Θ_{so} = source temperature for the heat pump

Θ_{si} = sink temperature for the heat pump

Θ_{hw} = used temperature of the hot water during phase 2 of EN 255-3

Θ_{cw} = cold water temperature of the cold water

By this correction method, both the COP values and the electricity input to cover the storage losses can be evaluated for varying source temperature.

Thermal storage losses stay constant for different source temperatures, so

$$Q_t = P_{es} \cdot COP_{standard} = P_{es,eff} \cdot COP_{eff}$$

eq. 67

where

Q_t = thermal losses of the storage

P_{es} = electricity input to cover storage losses at standard testing point

$COP_{standard}$ = COP at standard testing point

$P_{es,eff}$ = electricity input to cover storage losses at standard testing point

COP_{eff} = COP at changing source temperature

If COP_{eff} is replaced by eq. 64, the correction of the electricity input to cover the storage losses can be calculated according to eq. 68

$$P_{es,eff} = P_{es} \cdot \frac{COP_{C,standard}}{COP_{C,eff}}$$

eq. 68

where

$P_{es,eff}$ = electricity input for varying source temperature

P_{es} = electricity input at standard testing point

$COP_{C,standard}$ = Carnot COP at standard testing point

$COP_{C,eff}$ = Carnot COP at the varying source temperature

Formulated as a correction factor for the temperature influence on COP or electricity input to cover the storage losses, eq. 69 can be applied, which is taken from [4]

$$f_T = \frac{COP_{C,eff}}{COP_{C,standard}} = \frac{T_{si,out,eff} [K] \cdot (\Theta_{si,out,standard} - \Theta_{so,in,standard})}{T_{si,out,standard} [K] \cdot (\Theta_{si,out,eff} - \Theta_{so,in,eff})}$$

eq. 69

where

f_T = factor for temperature correction

$COP_{C,eff}$ = COP at effective conditions

$COP_{C,standard}$ = COP at (measured) standard conditions

$T_{si,out,eff}$ = effective sink outlet temperature [K]

$T_{si,out,standard}$ = sink outlet temperature at (measured standard) conditions [K]

$\Theta_{so,in,standard}$ = source inlet temperature at (measured standard) conditions

$\Theta_{so,in,eff}$ = effective sink outlet temperature

$\Theta_{si,out,eff}$ = effective sink outlet temperature

$\Theta_{si,out,standard}$ = sink outlet temperature at (measured standard) conditions

The COP at the effective temperature conditions can then be received by multiplication of the standard testing COP_t with the temperature correction factor f_T or a division by the factor f_T in the case of P_{es} .

However, in the real process the exergetic efficiency does not stay constant over the whole operation range, so the correction is only an approximation which shows good results near the standard testing point, but accordance with interpolated values deteriorate with increasing distance from the testing point. Therefore the method is well suited for temperature correction, where temperatures are not too far from the testing point. A comparison for 20 brine-to-water heat pumps with the exergetic efficiency was made. A correction from a measured value of the COP at B0/W35 to a COP at B5/W35 gave a mean deviation of 1.8%, a minimum deviation of 0.3 % and a maximum deviation of 5.5 % between the measured and calculated values at B5/W35.

4.4.2.3 Linear interpolation

Linear interpolation is the easiest approach. Advantages are the easy to use method, especially in the case of a hand calculation method. Problems occur, if not enough testing points are available, like in the case of the EN 255-2 [16]. However, a comparison with other interpolation methods does not deliver better results, either.

Fig. 16 shows a comparison of different interpolation methods, i.e. linear, cubic spline and 3rd degree polynomial, applied to an air-to-water heat pump measured according to Töss reglement [26].

Hence with regard to the objective of a hand calculation method, a linear interpolation of the values of the COP and the output capacity seems to be best-suited. It also gives more realistic results, if an extrapolation is applied.

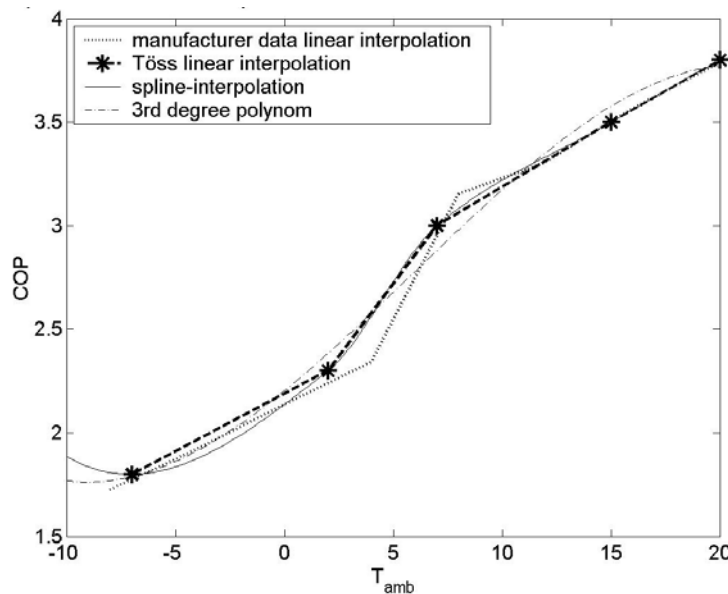

Fig. 16: comparison of different interpolation methods on the basis of testing points of WPZ Töss [11]

4.4.2.4 Influence of the resolution of considered operation points

The bin method performs an averaging in the respective bin, as operation conditions in the centre of the bin, at the operation point, determines the operation conditions of the whole bin. Therefore the number and position of the bins do have an impact on the result.

For a standard number and position of bins or operation points should be fixed to secure, that all calculations are performed in the same way. Investigation with different numbers of

bins and different bin positions have been done, which revealed, that the bins should be uniformly distributed over the whole operation range. If the bin positions are shifted to higher temperatures, a better SPF is calculated, since lower operation temperatures are averaged more the higher.

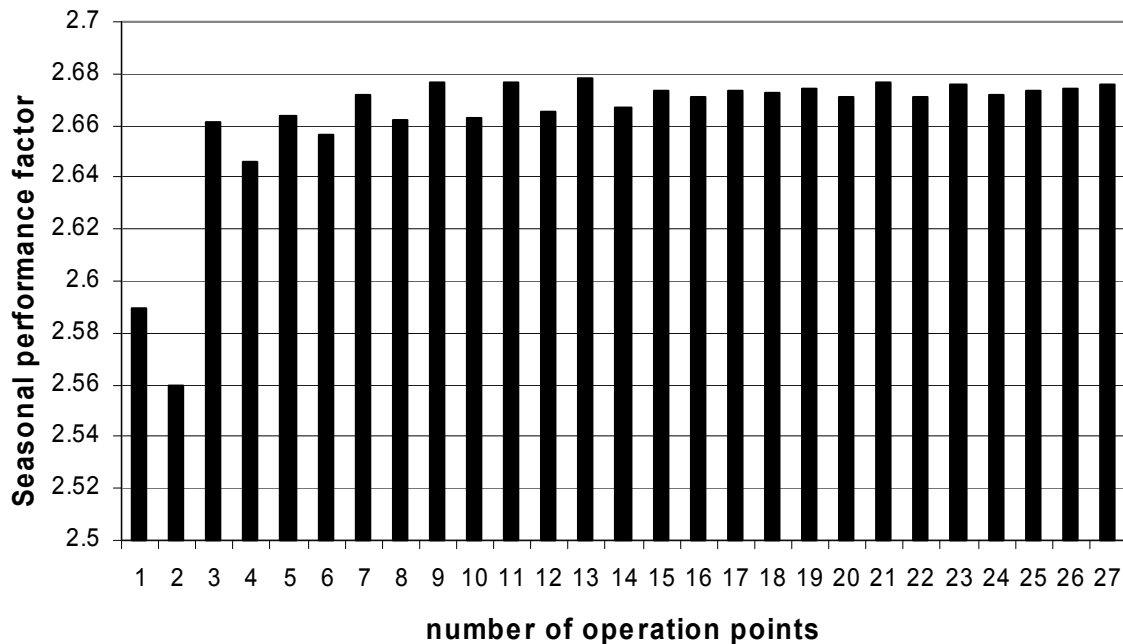

Fig. 17: Impact of the number of bins on the calculated SPF according to VDI 2067-6 [1]

Fig. 17 shows the results of calculations of the SPF according to the calculation method given in VDI 2067-6 detailed version [1] with a changing number, but uniformly distributed operation points. From a number of about five operation points on, e.g. five bins, the SPF-value does not change very much. A higher resolution of bins, as long as the bins are distributed uniformly, does not change the SPF significantly.

Therefore, a resolution of five bins seems a reasonable compromise between expense to perform the calculation and the exactness of the result.

4.5 Losses of the heat pump due to cyclic operation

The problem in the determination of cyclic losses is, that in European standardisation, no testing of the cyclic operation mode is defined as standard testing. EN 255 - 2 and EN 255- 3 only deliver the output capacity and the COP values for steady-state operation conditions. However, cyclic operation has been the subject of different research activities and in ASHRAE standard 116 [6] resp. ASHRAE 137 [47], an approach is already implemented based on a cyclic test described in ARI 210/240 [24]. Different approaches for cyclic operation at part load conditions are presented in this chapter.

4.5.1 Dynamic heat pump test

In Switzerland a test procedure to characterise the dynamic behaviour of heat pumps has been developed and tested in the project “Dynamic heat pump test” [12], [14]. The approach for the dynamic behaviour is characterised by five parameters, which are evaluated from a

test procedure by polynomial regression, which can be performed in standard software like MS-Excel. The approach implies, that the cyclic losses are dependent on the source and sink temperature and on the relative running and standstill time. The approach is formulated in three equations. The heat loss due to cyclic operation is given by eq. 70

$$Q_{l,cyc} = Q_{l,cyc,max} \cdot f_{dyn}$$

eq. 70

where

$Q_{l,cy}$ = heat energy loss due to cyclic operation

$Q_{l,cyc, max}$ = maximum heat energy loss due to cyclic operation

f_{dyn} = dynamic correction factor to characterise the cyclic operation

where $Q_{l,cyc, max}$ is defined by eq. 71

$$Q_{l,cyc,max} = a + b \cdot (\Theta_{si} - \Theta_{con,env}) + c \cdot \Theta_{so}$$

eq. 71

where

$Q_{l,cyc, max}$ = maximum cyclic losses

Θ_{si} = sink temperature

$\Theta_{con,env}$ = temperature of the environment of the condenser

Θ_{so} = source temperature

a, b, c = parameters to be identified by measurements

and f_{dyn} by eq. 72

$$f_{dyn} = \left[\frac{\left(1 - e^{-\frac{\alpha}{\beta}} \right) \cdot e^{\frac{\alpha-1}{\gamma\beta}}}{1 - e^{-\frac{\alpha}{\beta}} \cdot e^{\frac{\alpha-1}{\gamma\beta}}} \right] \cdot \left(1 - e^{-\frac{\alpha}{\beta}} \right)$$

eq. 72

with

$$\alpha = \frac{t_{op}}{t_{cyc}}$$

eq. 73

$$\beta = \frac{\tau_{on}}{t_{cyc}}$$

eq. 74

$$\gamma = \frac{\tau_{off}}{\tau_{on}}$$

eq. 75

where

t_{op} = operation time of the heat pump

t_{cyc} = cycle time of the heat pump operation (i.e. time of one on/off cycle)

τ_{on} = switch on time constant of the heat pump

τ_{off} = switch off time constant of the heat pump
 α = relative running time (running time divided by cycle time)
 β = ratio of the switch-on time constant to the cycle time
 γ = ratio of switch off to switch on time constant

The cycle time t_{cyc} is defined as the sum of the running time t_{op} and the following standstill time until the next heat pump start.

a, b and c are parameters to be identified in the test procedure. The maximum start-up loss (occurring at infinite running time) of the heat pump is dependent on the source and sink temperature. The higher the sink temperature and the lower the source temperature, the higher is the amount of energy to be supplied to heat-up the heat pump components, e.g. the condenser. This is expressed by the factor $Q_{l,\text{cyc,max}}$. If the heat pump is cycling, not all of the heat has to be supplied to the machine once again, because parts are recovered from the cycle before. This cyclic operation is described in the term of eq. 72 which is dependent on the heat-up time constant and the cooling down time constant of the machine as well as on the relative running time in each cycle. Details are described in [12] and [14].

To identify the relevant parameters the following test procedure is to be performed:

- 3 start-ups of the machine after a standstill of about eight hours are carried out at 3 different temperature combinations, e.g. A-10/W25, A10/W25 and A10/W45 for an air-to-water heat pump to identify the parameters for the maximum cyclic losses. To estimate the two time constants for switching-on and switching-off of the heat pump, two cyclic tests with 5 cycles each are performed with a cycle time derived from a provisional time constant identified in the start-up test.

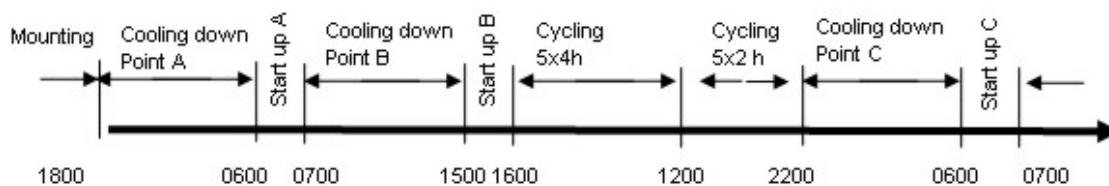

Fig. 18: Test procedure for the dynamic heat pump test (modified from [14])

The above test has been performed at the test centre WPZ for the KWT Swissline 40 NHB heat pump. Results are given in Tab. 10 and Tab. 11.

Tab. 10: parameters of the maximum cyclic losses according to eq. 71

parameter	a	b	c
[Wh]	-130.2	15.4	-9.6

Tab. 11: parameters of the dynamic correction factor according to eq. 72 with circulation pump running only when heat pump is running

Measurement	$f_{\text{dyn}}[-]$	$\tau_{\text{on}}[\text{s}]$	$\tau_{\text{off}}[\text{s}]$	$\gamma[-]$
1	0.020	13.2	691.6	52.4
2	0.038	12.7	1613.7	126.9
average	0.029	13.0	1152.7	89.7

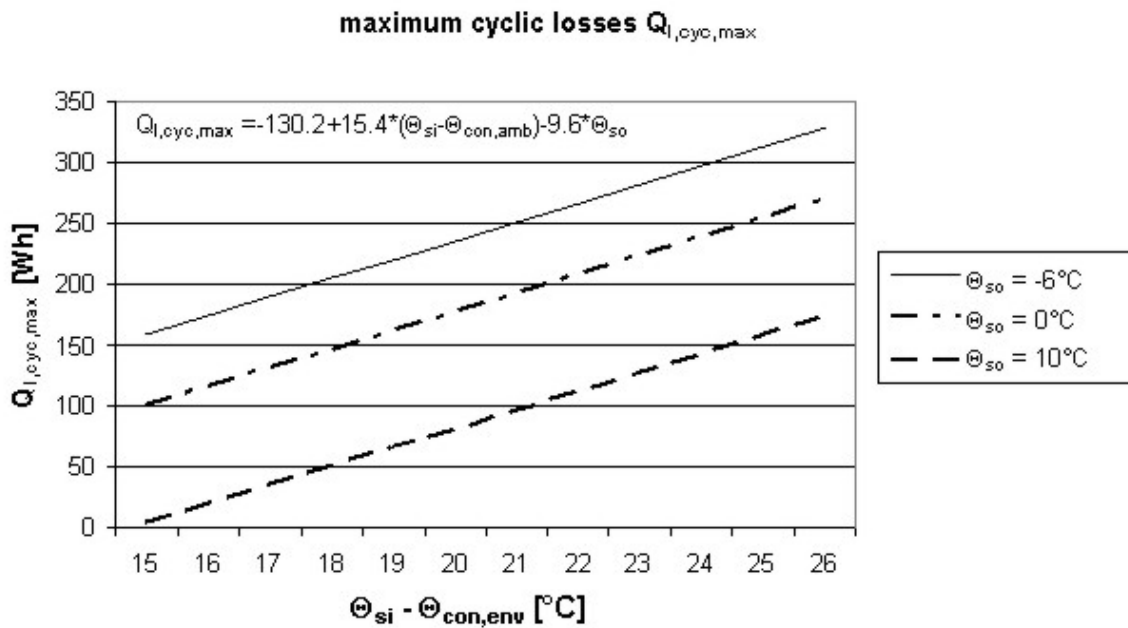

Fig. 19: Cyclic losses evaluated with reduced number of measurement points

The identified curves shown in Fig. 19 have been evaluated with a reduced number of measurement points. In this case the maximum cyclic losses occur at the lowest source temperature, which is according to the expectations.

Dynamic parameters are given in Tab. 11. The values delivered by the dynamic heat pump testing described in [14] are evaluated with a standing circulation pump, i.e. no heat is transported with the fluid after the switch-off of the heat pump. In most system configurations, the circulation pump runs through the whole heating period. Therefore, during the 3 start-ups to evaluate the maximum cyclic losses, the circulation pump has been operated.

The resulting switch-off time constants are shown in Tab. 12. The evaluation was made with a simple PT_1 approach. The switch off time constant with running circulation pump is then of the same order of magnitude as the switch-on time constant.

Tab. 12: switch-off time constant with running circulation pump

measurement	1	2	3	Average value
Switch-off time constant $\tau_{\text{off}}[\text{s}]$	11	12.8	16.7	13.5

4.5.2 ASHRAE 116 in combination with ARI 210/240

The American standard ASHRAE 116 [6] considers cyclic operation by determining a cyclic degradation coefficient C_D , which is derived by a cyclic test, described in the ARI standard 210/240 [24]. The cyclic test of ARI is performed together with the high temperature test, which corresponds to the steady-state testing in European standardisation according to EN 255-2 [16]. From the measured data the output capacity during the cyclic test is determined by eq. 76

$$q'_{cyc} = 60 \cdot Q_{mi} \cdot c_{pa} \cdot \int_0^{\Theta_i} [t_{a2}(\Theta) - t_{a1}(\Theta)] d\Theta / [v_n' \cdot (1 + W_n)]$$

eq. 76

where

q'_{cyc} = net integrated capacity [Btu]

Q_{mi} = air flow, indoor, measured [cfm]

c_{pa} = specific heat of air [Btu/lb·°F]

t_{a1} = temperature, air, entering indoor side, dry-bulb [°F]

t_{a2} = temperature, air leaving outdoor side [°F]

Θ = time [h]

v_n' = specific air volume at nozzle [ft³/lb]

W_n = humidity ratio [-]

and with this cyclic output capacity, the COP at cyclic operation is defined by eq. 77

$$COP_{cyc} = \frac{q_{cyc}}{3.413 \cdot E_{cyc}}$$

eq. 77

where

COP_{cyc} = cyclic coefficient of performance [-]

q_{cyc} = total integrated capacity [Btu]

E_{cyc} = total electrical energy used in cyclic test [J]

With these values and the heating load factor HLF which is defined by the eq. 78

$$HLF = q_{cyc} / \dot{q}_{thi} \cdot \Theta_{cyc}$$

eq. 78

where

HLF = heating load factor [-]

q_{cyc} = total integrated capacity (indoor –side data) for dry coil cyclic test [Btu]

\dot{q}_{thi} = total heating output capacity, indoor side data [Btu/h]

Θ_{cyc} = duration of time for one complete cycle consisting of one compressor ON time and one compressor OFF time [h]

The heating load factor used in the cyclic testing describes the ratio of energy delivered in cyclic operation (part load operation) to the energy that could be delivered in the full load operation during the whole cycle time, i.e. the case, if the heat pump would be running continuously the whole cycle time at full output capacity (full load operation)

The cyclic degradation coefficient C_D is calculated by eq. 79

$$C_D = \left(1 - \frac{COP_{cyc}}{COP_{ss}} \right) / (1 - HLF)$$

eq. 79

where

C_D = cyclic degradation coefficient

COP_{cyc} = COP in cyclic test according to ARI 210/240

COP_{ss} = COP from steady state high temperature test

HLF = heating load factor

4.5.3 Technical specification of prCEN/TS 14825

In the technical specification prCEN/TS 14825 [32] of CEN/TC 113/WG 7 a reduced capacity test procedure to deliver a COP at 50% operation time of the heat pump is described. The test is performed by operating a heat pump with on-off controller half of the time in on- and half of the time in off-state.

If the resulting output capacity is in the range of 40% to 60% of the rated output capacity according to EN 255-2 [16] or EN 255-3 [17] respectively and the COP does not differ more than 5% from the rated COP, the test is finished. If not, another test is performed, where the off-cycle is adapted to the deviation of the measured output capacity in the first test. The reduced capacity test is made with the same equipment as the standard testing according to EN 255-2 [16].

4.5.4 Measurements of Jacques Bernier

Measurements of Jacques Bernier reported in [25] are used by Feldmann [5] to give default values for the cyclic losses. Measurements of Bernier for different thermal capacities of the emission system showed that for emission systems with a big inertia like floor heating with stone floor, cyclic losses are negligible, since the running time of the heat pump is usually quite long. For systems with small inertia like convectors, cyclic losses are rather large. However, these systems will not work because control systems will not function with a quick rising return temperature and the heat pump would start cycling. Thus, in systems with a small inertia, a storage, most times in serial configuration, to increase the capacity is installed to secure the functionality of the control system. Thereby cyclic losses are reduced as well because of the increasing running time of the heat pump.

4.5.5 Approach for calculation of cyclic losses

For the calculation method, the approach of the dynamic heat pump test was adapted as a first approach.

However the parameters evaluated from the dynamic heat pump test procedure only describe the cyclic losses during one cycle. To obtain the total losses of the respective bin, the number of cycles per bin, i.e. the number of switches depending on the ambient temperature and the average running time during operation has to be known. As first approach a constant number of cycles evaluated from STASCH simulations [19] are taken.

Since there is no standard test procedure in Europe up to now, probably no measured values for the time constants of the heat pump will be available and default values have to be used. Measured values of the start-up time constant are given in a range of 20 – 180 seconds. Switch-off time constants have to be distinguished between switching-off of the heat pump with running circulation pump, so the remaining heat in the heat pump is transferred to the fluid, or standing pump, so the heat is transferred to the environment and cannot be used. In

the case of standing pump, time constants are much longer and are given with 1200 seconds [12]. With running pump, the time constant of the measurement gave a mean value of 13 seconds, so in the range of the start-up time constant.

4.6 Test procedure for simultaneous operation

The existing standards for testing heat pumps cover only the single heating operation according to EN 255-2 [16] or the single hot water operation according to EN 255-3 [17]. There are approaches to calculate the alternate combined operation based on these measurements, where the heat pump is switched from the heating mode to the hot water mode in case of domestic hot water demand and in principle works only either in single heating or in single domestic hot water mode. However, simultaneous combined operation cannot be covered by the existing standard. A test procedure for the simultaneous operation had thus been developed at the Swiss national test centre WPZ Töss, which is described in detail in [7]. This chapter gives a summary and conclusions on the test procedure with respect to the calculation method.

4.6.1 Developed test procedure for simultaneous operation

EN 255 has been adapted to a test procedure for simultaneous operation in that way, that the defined cycle in EN 255-3 is performed during the operation of the heating system. The problem that occurs in this case is, that allocation of the electrical energy input to either heating or domestic hot water operation cannot be performed.

With regard to easy comparison of the results to measurements of the single operation according to EN 255-2 for single heating operation and EN 255-3 for single domestic hot water operation, the assumption that the COP for heating operation is not influenced by the simultaneous domestic hot water operation has been made.

For the calculation of the SPF a hot water output capacity of the heat pump is required to give a basic idea, which fraction of the domestic hot water is produced in simultaneous operation (see approach for combined operation in chapter 3.4). As the standard evaluation of EN 255-3 does not provide a hot water output capacity of the heat pump, it is calculated according to eq. 80

$$\phi_{hp,DHW} = \frac{Q_{DHW,phase2}}{t_t}$$

eq. 80

where

$\phi_{hp,DHW}$ = capacity of the heat pump in domestic hot water operation

Q_{DHW} = domestic hot water energy demand covered by the heat pump during phase 2 of EN 255-3

t_t = time in phase 2 of the EN 255-3

This value is not exact, as the entire time of phase 2 is taken, whereas the loading of the storage starts after a reaction time. However, this reaction time is small, so that this calculation of the output capacity is a good approximation of the real value with a great advantage: the simultaneous operation is described by two parameter sets, output capacity and COP, for each the heating and domestic hot water in simultaneous operation. Together with the heat pump characteristic in each single heating and single domestic hot water the characteristic is described. Measurements are carried out according to EN 255-2 and

EN 255-3.

Fig. 20 shows an overview of the entire test procedure, the evaluation to undertake and the principal values delivered by the single testing cycles.

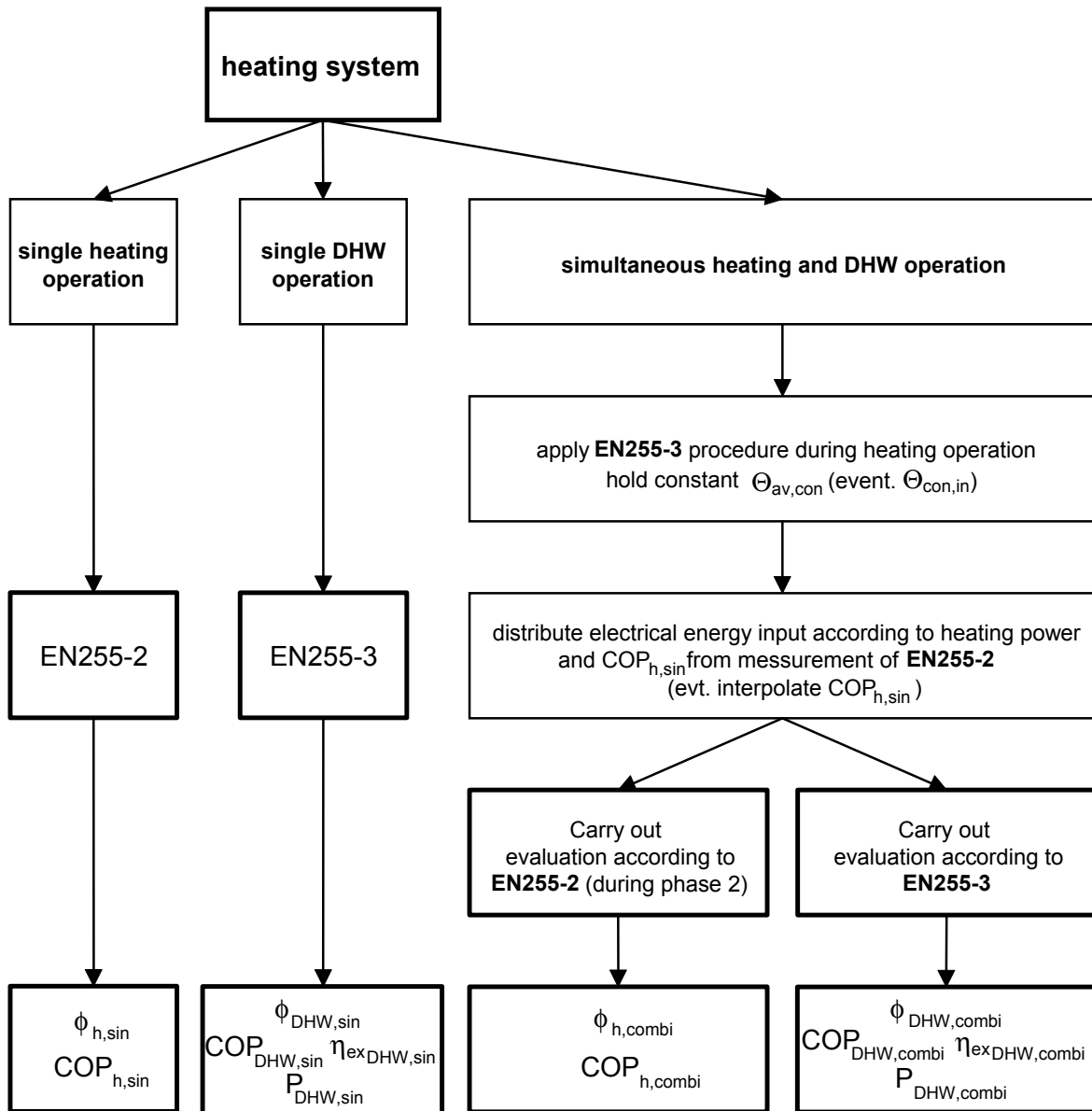

Fig. 20: scheme of the test procedure for simultaneous operation (modified acc. to [7])

Further results from the measurements are $P_{DHW,combi}$, the electricity input to the heat pump to cover standby losses of the storage, and additional $\eta_{ex,DHW,combi}$, the exergetic efficiency to characterise the process. $\eta_{ex,DHW,combi}$ is evaluated, since minimum and maximum domestic hot water temperature is not defined in EN 255-3, so systems with lower DHW output temperature have an advantage to systems with higher output temperature. $\eta_{ex,DHW}$ is not evaluated in EN 255-3 and introduced in the test procedure according [7].

For the calculation of the seasonal performance factor, the distribution is not relevant, as only the total energy input for the respective energy output in form of heating or domestic hot water heat is important.

Thus the following changes have been introduced for the test procedure for simultaneous operation with regard to the standard testing according to EN 255 in [7]:

changes in EN 255-2:

1. Measured COP-values according to EN 255-2 depend on the average temperature during the heat transfer in the condenser. However, EN 255-2 defines only the supply temperature of the heating system, i.e. the outlet temperature of the condenser, but not the volume flow. Measured COP-values tend to be better with small volume flow rates in the condenser, as the average temperature decreases. Thus the temperature difference over the condenser is limited to a maximum of 10°C according to [26].
2. For combined operation an average temperature $\Theta_{av,con}$ has to be defined. This is necessary, since in the real testing the defined supply temperature, i.e. possibly cannot be kept constant, as interaction with the domestic hot water cycle may have an influence on the output capacity of the heating operation. The technical viable solution to perform the measurements is to control the inlet temperature and calculate an average temperature during the evaluation of the COP-values. The COP-values have to be interpolated from a characteristic $f(\Theta_{so,in}, \Theta_{con,av})$. Therefore the COP in combined operation differs from the COP in single heating operation and both data set (heating and hot water operation) are linked for the simultaneous operation (see details in [7]).

changes in EN 255-3:

1. calculation of an output capacity by the measurements of phase 2 in the above described way (see details in [7])
2. Definition of a hot water extraction temperature during phase 2
3. calculation of the exergetic efficiency to take into account different temperature levels of the hot water extraction based on this calculated temperature (for exergetic efficiency, see chapter 4.4.2.2)
4. shift of the end of phase 3 to a completely loaded storage (switch-off of controller after loading in phase 3)

4.7 Factor of simultaneous operation

The factor describes how long simultaneous operation, i.e. space heating and domestic hot water production, takes place in combined systems that can provide both operation modes simultaneously. The more simultaneous operation takes place, the better is the performance of the system, as characteristics of the heat pump and the COP are increasing in simultaneous operation. Thus an upper limit of the system performance would be the most possible simultaneous operation in the combined mode, while a lower limit would be the least or no combined operation.

The degree of simultaneous operation depends basically on the runtime of the heating and the domestic hot water part.

The runtime of the domestic hot water system depends for systems with condensate subcooling on the following parameters:

- Output capacity of the hot water heat pump
- Energy requirement for domestic hot water
- Hot water tapping profile
- Control system of the hot water storage (hysteresis)

The runtime of the heating system depends basically on

- Output capacity of the heating heat pump
- Control strategy of the space heating system (Hysteresis controller, pulse width modulation)
- Controller settings
- Capacity of the heat distribution system
- System Configuration (heating storage or not)

4.7.1 Theoretical considerations

Dimensioning

From the point of view of the dimensioning, both the heating and the domestic hot water operation shall run as long as possible, as this increases the probability for simultaneous operation. As hot water energy requirements are normally lower than heating requirements, the hot water heat pump should be smaller in the ratio of the two demands, e.g. for retrofit buildings in the range of one fourth of the heating requirement. For the part of the heating heat pump, an under dimensioning could extend the running time for the heating part. Simulations in the STASCH-Project [18] showed that a smaller dimensioning of the heat pump of up to about 20% in comparison to SIA 384/2 [9] can still cover the heating requirement of the building, but the running time of the heat pump increases.

Control strategy

Control has a great impact on the operation of the two parts. A hysteresis controller for the DHW storage loading has a lower potential of combined operation than a hysteresis controller that has information about the state of the heating system. An even higher potential for combined operation would have system configurations, that contain a heating buffer storage, because the heating operation can be partly adapted to the domestic hot water demand. Concepts of pulse width modulation, that integrate the thermal mass of the building as storage or systems with a parallel heating buffer storage, should be able to reach a factor for simultaneous operation near 100% if for the control of the heating domestic hot water demand is considered.

4.7.2 Results from simulations

The factor for simultaneous operation is an input to the calculation method. However, to give some ideas about the impact of the different influences on the simultaneous operation and for an estimation of the factor, simulations have been carried out. The heating side is modelled by a load profile, which has been taken from the STASCH simulation. To separate the building from the system side, a parallel storage configuration has been chosen. Hence for the system it is the same, if the heating load comes from a load profile or a building model, as the system is only connected to the storage and not to the building itself. However a load profile speeds up the simulations considerably.

The heat pump used corresponds to the measurements of the simultaneous operating system, which is described in chapter 5.1.2. The simultaneous operation is modelled by the two characteristics of the heat pump, which are switched depending on the control state of the heating and the hot water side.

The following cases were investigated:

- A hysteresis controller, which has no information about the state of the heating and only controls the domestic hot water storage loading.
- An optimised hysteresis controller, that has information about the state of the heating and tries to heat up the domestic hot water in times where the heating is switched on, i.e. tries to optimise the simultaneous operation. If the heating system is running and the storage is full or partly unloaded, even if the switch-on point of the hysteresis is not reached, the simultaneous operation was initiated. However, to avoid cycling of the on-off controller, a minimum hysteresis had to be defined, so not all possible energy input can be realised.

Results of the simple hysteresis controller simulations showed, that only 37% of the total hot water requirement has been produced in combined operation, whereas about 58% simultaneous operation occurred in the case of the controller who had information about the state of the heating.

Fig. 21 and Fig. 22 show the simultaneous operation in the case of the hysteresis controller, which does not evaluate the information about the state of the heating system (Fig. 21) and an optimised controller, which takes into account the state of the heating system to maximize the simultaneous operation (Fig. 22).

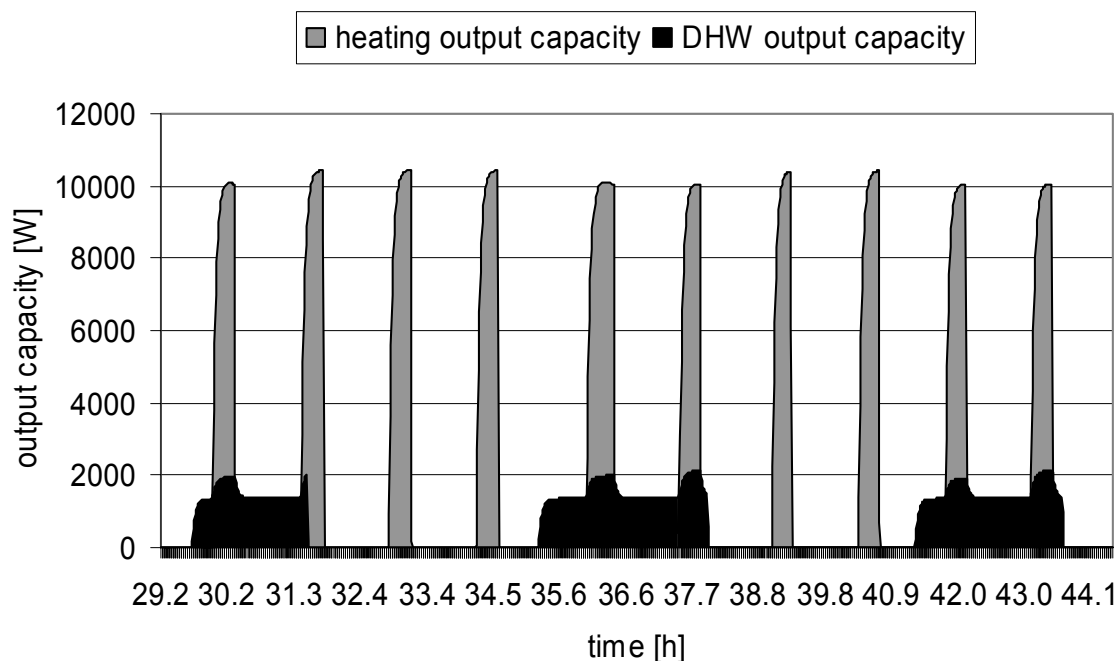

Fig. 21: simultaneous operation in case of standard two point hysteresis control

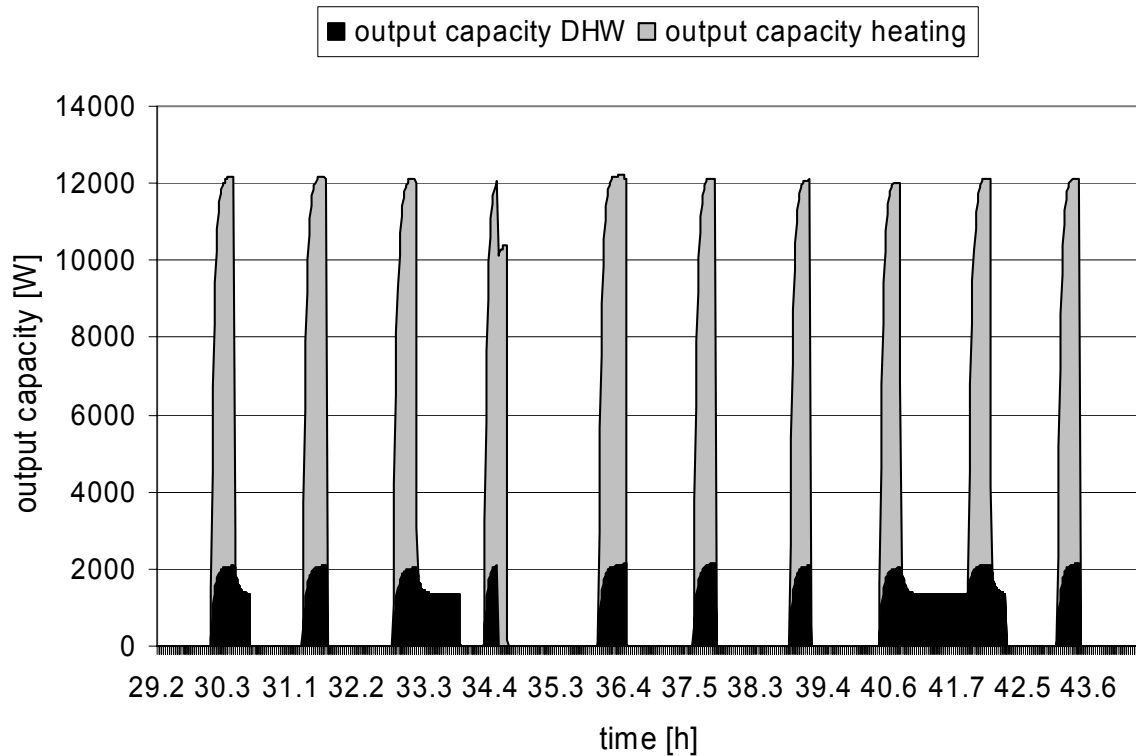

Fig. 22: simultaneous operation in case of optimised controller

4.8 Comparison of the calculation method with simulations

Comparison of the single heating mode has been performed with the results of the STASCH project [19]. In the STASCH project different system configurations have been investigated, so that the impact of the different configuration on the calculation method can be seen. The basic input data are listed in Tab.1. Details of the system configuration and the modelling of the systems are described in [19]. The comparison of the results of the simulations with the results of the calculation method is shown in. Tab. 13

Tab. 13: Comparison of STASCH- Simulations and the calculation method

	Simulated SPF	Calculated SPF	Abs. Deviation Sim - Calc	Rel. Deviation Sim - Calc
STASCH P2	3.19	3.01	0.18	6.0 %
STASCH P5	3.06	2.87	0.19	6.2 %
STASCH P7	3.04	2.86	0.18	5.9 %
STASCH P9	2.98	2.84	0.14	4.6 %
STASCH P11	2.76	2.55	0.21	7.6 %
STASCH P13	2.68	2.51	0.17	6.3 %
Mean deviation			$\Delta = 0.18$	6.1 %

In the following paragraph the different system configuration are shortly described.

- The first four system configurations contain a low-temperature heat emission system, i.e. a floor heating.
 - STASCH P2 is the simplest system without serial or parallel storage. For the function of the system, an emission system with a adequate inertia, e.g. a floor heating in a modern building is essential.
 - STASCH P5 is a system with floor heating and thermostatic valves. Investigations on the fraction of the controllable emission surface have been carried out in this system configuration.
 - STASCH P7 is a system with serial storage, thermostatic valve and an overflow valve to secure a minimum mass flow in a heat pump cycle.
 - STASCH P9 contains a parallel heating storage, i.e. the heat pump, the distribution and the emission system are decoupled.
- STASCH P11 and STASCH P13 refer to retrofit buildings with radiator emission system, i.e. a system with less inertia.
 - STASCH P11 is the counterpart to P2, a system configuration without storages.
 - STASCH P 13 is a the counterpart to P7, a system with serial storage.

The mean simulated SPF_s of STASCH-simulations are in the average 6% higher than the SPF_s calculated with the FHBB method. On the one hand, this can be explained by uncertainties in the approaches that have been made, e.g. consideration of cyclic operation. On the other hand, the bin-approach itself is limited, as certain aspects, e.g. influence of control in case of intermediate heating, cannot exactly be considered. For this reason a hand calculation method cannot be arbitrarily extended and the step to the computer has to be made to receive better exactness of the results.

The hydraulic schemes of the system configurations are shown on in Fig. 23 to Fig. 25

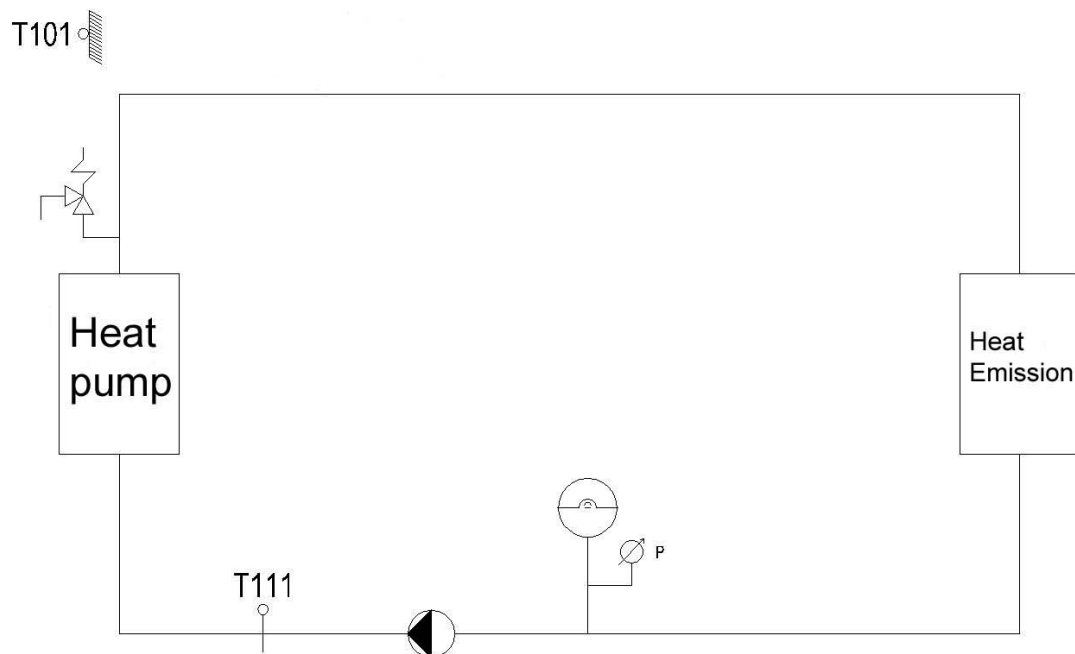

Fig. 23: hydraulic scheme of the system configuration P2 and P5

5 CALCULATIONS FOR THE TWO MEASURED SYSTEMS

In the parallel project at WPZ Töss [7] two combined working system, one in alternate operation and one in simultaneous operation, have been measured in detail to develop a test procedure for combined working systems based on existing standards. In this chapter the measured systems are described, the results of the measurements are summarised and based on the evaluated heat pump characteristic seasonal performance calculations are carried out.

5.1 System description

5.1.1 Alternate operating system

The schematic hydraulic diagram of the system for alternate production is shown in Fig. 26.

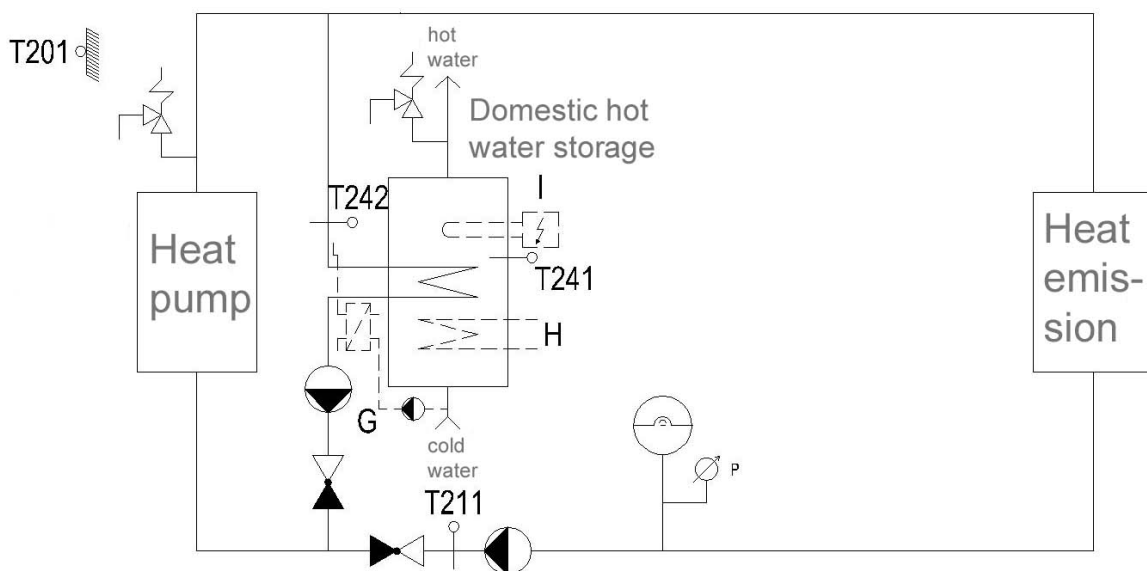

Fig. 26: schematic hydraulic diagram of the system with alternate hot water production (modified from [19])

The system has a parallel domestic hot water storage with a hot water priority control, i.e. in case of hot water demand, the supply of the heating system is interrupted until the hot water demand is covered. This system configuration is wide – spread on the Swiss market.

Tab. 14 gives an overview of the basic system data of the alternate working system.

Tab. 14: System characteristic of the alternate working system (taken from [7])

Heat pump data	
Manufacturer/ type	Novelan, Siemens SIC 9M / brine-to-water
Output capacity at B0/W35	9.1 kW
Electrical power input at B0/W35	2.1 kW
COP at B0/W35	4.4
Compressor type	Scroll, fully hermetic
condenser	Flat plate heat exchanger
evaporator	Flat plate heat exchanger
Injection valve	Thermostatic
refrigerant	R 407 C
Source working fluid	25% ethylen glycole
DHW Storage	
volume	300 l
Heat exchange area	3.5 m ²
Thermal insulation (PUR foam)	50 mm
Height (incl. insulation)	1.44 m
Diameter (incl. insulation)	0.65 m

5.1.2 Simultaneous operating system

Fig. 27 shows the hydraulic scheme of the simultaneous operating system.

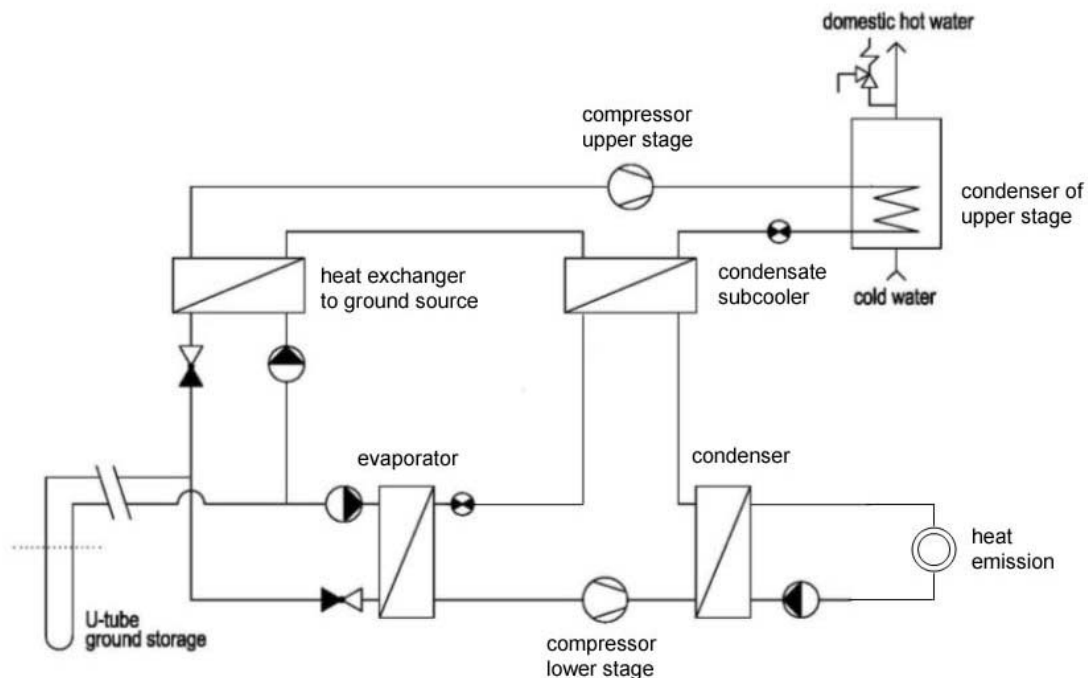

Fig. 27: configuration of the simultaneous operating system

The machine consists of two heat pumps mounted in a cascade. The lower one has a bigger compressor and is used for space heating. The upper one has a smaller compressor and is used for the domestic hot water. The smaller heat pump has the possibility to take the heat from the condensate of the bigger heat pump, i.e. from the return of the condenser by subcooling the condensed refrigerant. Thus by this subcooling, the hot water can be produced more efficiently in simultaneous operation with the heating, since the temperature level of the source is higher. The condenser of the smaller heat pump is located directly in the domestic hot water storage. In single hot water operation mode, e.g. during summer time, the heat is extracted directly from the ground source by a second heat exchanger.

An illustration of the principle of the condensate subcooling in the log p-h-diagram is shown in Fig. 28

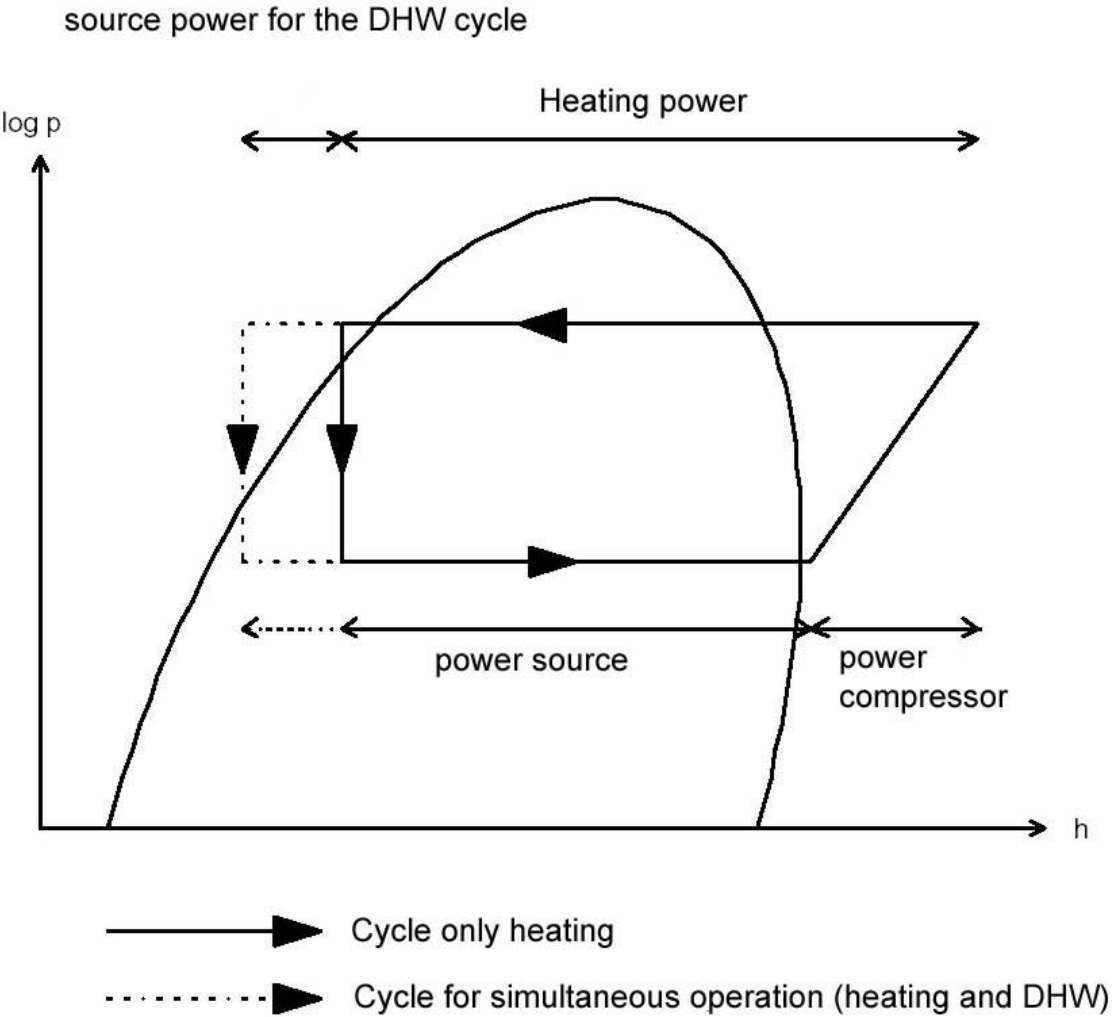

Fig. 28: condensate subcooling in the log p – h diagram (modified from [7])

The basic system data are gathered in Tab. 15.

Tab. 15: system data of the simultaneous working system (taken from [7])

Heat pump heating	
Manufacturer / type	KWT, Swissline 40 NHB / brine-to-water
Output capacity at B0/W35	9.5 kW
Electrical power input at B0/W35	2.1 kW
COP at B0/W35	4.6
Compressor type	Scroll, fully hermetic
condenser	Flat plate heat exchanger
evaporator	Flat plate heat exchanger
Injection valve	Thermostatic
Refrigerant	R 407 C
Source working fluid	25 % ethylen glycole
Domestic hot water heat pump	
Manufacturer / type	KWT, SC 15 G
Output capacity	2.2 kW
Electrical power input	0.7 kW
COP	3.1
Compressor type	Reciprocating piston, fully hermetic
condenser	Heat exchanger in DHW storage
evaporator	Flat plate heat exchanger
Injection valve	Thermostatic
Refrigerant	R 134 a
DHW Storage	
volume	200 l
Thermal insulation	50 mm
Height (incl. thermal insulation)	1.06 m
Diameter (incl. thermal insulation)	0.56 m

5.2 Discussion of the measurements of the two systems

In this paragraph a summary of the results of the measurements made in the parallel project at WPZ Töss is given. A detailed discussion of the measurement can be found in the final report of the project.

5.2.1.1 Heat pump characteristics

The measurements of the COP-values of the systems made in the project "test procedure for the combined space and domestic hot water heating" [7] at the WPZ Töss include entire measurements according to EN 255-3 [17], which deliver a COP-value for the generation of domestic hot water COP_t .

As this value is explicitly corrected by the electricity demand of the heat pump to cover the storage losses, the values are independent of the attached DHW storage.

Both systems are equipped with a programmable control device, so for both systems the limitation for the hot water operation was set to 55°C to switch-off the heating of the storage and 50°C to switch-on the heating of the DHW storage water. Thus the tapped hot water temperature, which is not defined in single and simultaneous operation mode during the measurements is set to $\Theta_{h,DHW} = 55^\circ\text{C}$.

For the Novelan system measurements of the complete EN 255-3 cycle were made for the testing point B0/* and B0/W35, where the asterisk refers to the fact, that the heating is not in operation, e.g. the system is in single DHW operation mode and the supply temperature of the heating system is not defined. The expression “W35” is related to the supply temperature of the heating system in simultaneous operation, e.g. when the test cycle of EN 255-3 is applied during heating operation. As the system works alternately either in domestic hot water or in heating mode, the COP values “should” be the same. The real behaviour of the system is described in chapter 5.2.1.2 and explained in more detail in [7].

For the KWT (simultaneous system), the complete EN 255-3 cycle at the testing points B0/*, B0/W35 and B0/W50 were measured.

Moreover, for the KWT system, measurements of phase 2 of the EN 255-3 cycle at the source temperatures $\Theta_{so} = -5^\circ\text{C}$, $\Theta_{so} = 0^\circ\text{C}$, $\Theta_{so} = 5^\circ\text{C}$ and the supply temperatures of simultaneous heating at $\Theta_{si} = 35^\circ\text{C}$ and $\Theta_{si} = 50^\circ\text{C}$ were made. To correct this phase 2 measurements to the COP_t -value according to entire EN 255-3 cycle, the electricity input to cover the standby losses are taken from the measurement of the complete cycle and assumed constant as well for the other testing points with the respective supply temperature of the heating system, i.e. single operation, $\Theta_{si} = 35^\circ\text{C}$ and $\Theta_{si} = 50^\circ\text{C}$ for the simultaneous operation. With this assumption and the measurements of phase 2, the COP_t can be calculated. The differences of the above approach with a correction of the COP values with an electricity input, that is itself corrected by an exergetic efficiency, is small, so the approximation of the above approach is quite good.

For both systems the EN 255-3 measurements have been used for the hot water operation. In case of the KWT, the output capacity could be taken from the measurements of phase 2 and is interpolated for changing source and sink temperatures. For the Novelan system only one point at 0°C was measured. As the Novelan system works in alternate mode, the change of the output capacity was derived by the gradient of the output capacity of the heating mode. The heat pump characteristic of the Novelan system according to the measurement of EN 255-2 and EN 255-3 are given in Tab. 16 and Tab. 17, the characteristics of the KWT system according to EN 255-2 and EN 255-3 and the described test procedure in chapter 4.6 are given in Tab. 18, Tab. 19 and Tab. 20.

Tab. 16: Novelan SIC 9M, heating characteristic according to EN 255-2

Novelan							
Testing point		B5/W35	B0/W35	B-5/W35	B5/W50	B0/W50	B-5/W50
Heating capacity	W	10'596	9'477	8'406	10'444	9'282	8'110
Electrical power	W	2'164	2'179	2'203	3'067	3'092	3'117
COP	-	4.9	4.35	3.82	3.4	3	2.6

Tab. 17: Novelan SIC 9M, DHW single characteristic according to EN 255-3

Novelan			
Testing point		B0/*	B0/W35
Heating capacity	W	7'069	7'147
Electrical power for domestic hot water	W	2'309	2'365
COP _t	-	3.06	3.02
Exergetic efficiency	-	0.31	0.31
Electrical power input for storage losses DHW	W	55	55.3

Tab. 18: KWT Swissline 40 NHB, heating only characteristic according to EN 255-2

KWT heating only							
Testing point		B5/W35	B0/W35	B-5/W35	B5/W50	B0/W50	B-5/W50
Heating capacity	W	10'344	9'015	7'883	9'719	8'604	7'574
Electrical power	W	1'990	2'022	2'058	2'864	2'918	2'973
COP	-	5.20	4.46	3.83	3.39	2.95	2.55

Tab. 19: KWT Swissline 40 NHB, DHW single characteristic according to EN 255-3

KWT DHW only				
Testing point		B5/*	B0/*	B-5/*
Heating capacity	W	1'384	1'141	665
Electrical power DHW	W	585	548	493
COP _t	-	2.65	2.36	1.54
Exergetic efficiency		0.2	0.24	0.16
Electrical power input for storage losses DHW	W	56.5	62.4	68.3

Tab. 20: KWT Swissline 40 NHB, DHW simultaneous operation acc. EN 255-3

KWT DHW simultaneous							
Operation point		B5/W35	B0/W35	B-5/W35	B5/W50	B0/W50	B-5/W50
Heating output capacity	W	10'313	9038	7'838	9'713	8555	7'530
DHW capacity	W	1'829	1'751	1'679	2'039	2'133	2'093
Total electrical input		2'622	2'630	2'660	3'444	3'489	3'579
Electrical input heating(calculated)		1'949	1'981	1'983	2'862	2'858	2'956
Electrical input DHW (calculated)		673	649	677	582	631	623
COP _t	-	2.86	2.70	2.62	3.69	3.38	3.53
Exergetic efficiency		0.23	0.28	0.30	0.29	0.35	0.41
Electrical power input for storage losses DHW	W	33.4	36.3	39.7	26.9	29.3	32.9

The bold COP-values are the results of the measurements of the complete EN 255-3 cycle, the others COP values have been measured for phase 2 and have been corrected for the electricity input to cover storage losses with the above described approach. These values are contained in the tables in italic letters.

Further evaluation of the measured data in [7] of the systems to be investigated led to the following conclusions:

5.2.1.2 Alternate operating system

The storage loses energy to the intermediate storage loading cycle. Therefore the electrical input for single and combined operation (measurements of hot water cycle according to EN 255-3 during (interrupted) heating operation) to cover stand-by losses is only occasionally equal. As conclusion as well in alternate operating systems, the application of the test procedure for simultaneous operation could be sensible, but an adequate evaluation of the result taking into account the interaction of the heat pump and the storage is required, as well.

5.2.1.3 Simultaneous operating system

A measurement of the internal electricity input to the small compressor of the domestic hot water system gave the possibility to evaluate the real distribution of the total electricity input to the two heat pumps, mounted in the cascade of the KWT system. Results reveal, that the real distribution differs significantly from the approach that the COP of the heating operation stays constant during simultaneous operation.

Tab. 21: comparison of real and assumed data for simultaneous operation (taken from [7])

	B0/W35 COP_h = const. calculated	B0/W35 measured	B0/W50 COP_h = const. calculated	B0/W50 measured
Output capacity heating	9038	9038	8555	8555
Output capacity DHW	1751	1751	2133	2133
Electrical input heating	1981	2098	2858	2911
Electrical input DHW	649	535	631	581
COP EN 255-2	4.56	4.31	2.99	2.94
COP EN 255-3	2.70	3.27	3.38	3.67
Exergetic efficiency	0.28	0.34	0.35	0.38
Electricity input to cover storage losses	36.3	32.8	29.3	26.6

The calculated values in Tab. 21 refer to the assumption that the COP in heating mode is not changed in simultaneous operation either. The measured values show the real behaviour of the system.

The amount of tapped hot water has an influence on the COP values. Thus the method shall be applied to two different amounts of tapped water, e.g. 30% and 60%. This extension is not very time-consuming but gives useful information on the impact of the tapping.

The entire characteristic of the two measured systems is documented in [7].

5.3 Seasonal performance calculation for the two systems

Even though a detailed validation of the method has not been carried out, yet, preliminary calculations of the seasonal performance factor were carried out at different boundary conditions for the two systems that were measured in the project "test procedure for the combined space and domestic hot water heating" [7]. As thorough validation is to be carried out in the future, no precise statement on the exactness of the results can be given here. Preliminary comparisons gave an exactness in the range of **5% - 10%**.

5.3.1 System configuration

Calculations are carried out for a low-energy building according to the Swiss MINERGIE standard and a retrofit building. In the low energy building, no heating buffer storage is included and so the systems correspond to the hydraulic schemes shown in Fig. 26 and Fig. 27. In the retrofit building, an additional heating buffer storage in parallel is integrated.

5.3.2 Boundary conditions

5.3.2.1 Parameter heating and domestic hot water

Tab. 22 shows the boundary conditions for the heating and hot water system.

In the case of the low-energy building, a monovalent operation is possible. In the case of the retrofit building, a monoenergetic parallel operation is applied for space heating. As both heat pumps can deliver the heat up to a temperature of 55°C, no electrical back-up heater for the domestic hot water mode is applied.

For the heating mode, meteo data have been evaluated for the heating period from beginning of September until end of April, i.e. temperatures below the upper temperature limit of heating from the beginning of May up to end of August are not considered. This refers to heating systems that are switched-off in summertime, so that even at temperatures lower than the upper temperature limit for heating, the heating system does not operate. For a heating limit of 15°C, the resulting heating operation is 217 days. For the domestic hot water mode, the operation period is 8760 hours.

Tab. 22: parameters for the heating and hot water system

Parameter	Low-energy building acc. MINERGIE	Retrofit building
Meteorological data	Zurich SMA	Zurich SMA
Heating system		
Design building load (SIA 384/2)	5 kW	8.8 kW
Design outside temperature (SIA 384/2)	-11 °C	-11 °C
Heating energy demand (SIA 380/1)	10'039 kWh/a	20'158 kWh/a
Interruption of electricity supply	3 hours/day	3 hours/day
Design room temperature	20 °C	20 °C
Settings of the heating curve		
Supply at design outside temperature	(-11°C/35°C)	(-11°C/55°C)
Supply at heating boundary temperature	(15°C/25.2°C)	(15°C/28.7°C)

Tab.22: parameters for the heating and hot water system (continued)

Domestic hot water system	Low-energy building acc. MINERGIE	Retrofit building
Cold water temperature	15 °C	15 °C
Hot water temperature with heat pump	55 °C	55 °C
Tapped amount of hot water (acc. to SIA 385/3, average standard, average consumption)	45 liters/person (at 55 °C)	45 liters/person (at 55 °C)
Number of persons	4	4
Hot water energy demand	3'053 kWh/a	3'053 kWh/a
Fraction of DHW on energy demand	23.3 %	13.2 %

5.3.2.2 Auxiliary energies

For the auxiliary energies, the values depicted in Tab. 23 have been used. As the pumps are integrated in the commercial systems, i.e. the system is available as a unit on the market with built-in pumps. The values of all pumps are taken from manufacturer catalogue [52] in case of the Novelan system. In case of the KWT system, the measured values of WPZ Töss [7] were used for the source pump; the other pumps are set to the same values as in the Novelan system. The rated power of the pumps is shown in Tab. 23.

Tab. 23: rated power of the pumps for auxiliary energy calculation

Auxiliary component	Novelan SIC 9M	KWT Swissline 40 NHB
Circulation pump of heat source	245 W	150 W
Circulation pump of heat distribution system	90 W	90 W
Circulation pump for buffer storage loading	90 W	90 W
Circulation pump for DHW storage loading	90 W	-

Parts of these auxiliary energy consumptions are already included in the COP according to EN 255-2 and EN 255-3 respectively, namely the power to overcome the pressure drop in the evaporator in case of EN 255-3 and of the evaporator and condenser in case of EN 255-2. Thus, only the external power is taken into account.

The auxiliary energy, that is included in the COP values, can be calculated according to EN 255 [16], [17] by eq. 18.

In contrast to the EN 255 a pump efficiency η_{aux} of 0.2 is used in the measurements of WPZ Töss according to the Töss reglement [26].

For the Novelan and KWT heat pump, the measured pressure drop and rated volume flow are given according to Tab. 24.

Tab. 24: Pressure drop and rated volume flow according to the WPZ-Töss measurements [7]

	Pressure drop evaporator [mbar]	Rated volume flow evaporator [m ³ /h]	Pressure drop condenser [mbar]	Rated volume flow condenser [m ³ /h]
Novelan	185	2.2	85	0.89
KWT	57	2.4	4.35	0.88

The values are averaged for the six standard measurement points of WPZ Töss (see Fig. 4) with the source temperatures $\Theta_{so} = -5^{\circ}\text{C}$, $\Theta_{so} = 0^{\circ}\text{C}$ and $\Theta_{so} = 5^{\circ}\text{C}$ at the supply temperatures $\Theta_{si} = 35^{\circ}\text{C}$ and $\Theta_{si} = 50^{\circ}\text{C}$ for brine-to-water heat pumps.

5.3.2.3 Operation points and source temperature

Eight operation points are used for the calculation. Five of these are relevant for the operation of the heating system, since the temperature is below the upper temperature limit for heating.

The source temperature was derived by a linear fit of the time-dependent profile of Eugster [49], see chapter 4.2.2. The operation points and the corresponding source temperature is shown in Tab. 25.

Tab. 25: Operation points and corresponding source temperature

Operation point [°C]	-7	-2	3	8	12	18	24	30
Lower temperature limit of the bin [°C]	-11	-5	1	6	10	15	21	27
Upper temperature limit of the bin [°C]	-5	1	6	10	15	21	27	33
Source temp. [°C]	0.5	1.2	2	2.7	3.3	4.2	4.5	4.5

5.3.2.4 Storage losses

For the heating mode, the storage losses are given as thermal losses, as the heating buffer storage is not integrated in the system, so a 300 l storage with an (U·A)-value of 2.4 W/K according to the Swiss energy directive [51] is used to calculate the thermal storage losses.

In case of the DHW storage, the storage is a built-in storage, which is delivered with the system and thus measurements of EN 255-3, which delivers the electricity input to cover the storage losses, have been used.

To derive the thermal losses from the electrical values, a correction with the approach of the exergetic efficiency described in chapter 4.4.2.2 was applied to find the COP values during storage loading. For the Novelan system, values of the intermediate cycle were measured, so the COP of the storage loading could be evaluated from the measurements and was in good accordance to the calculated one. Hence for the KWT system the same approach was applied to calculate the thermal power.

5.3.3 Assumptions

The following assumptions were made to perform the calculation

- the heating mode requires four on/off cycles of the heat pump per day
- the hot water mode requires one on/off cycle per day
- in simultaneous operation, no auxiliary energy input to the hot water part is considered. The pumping energy of the source pump is entirely accounted to the SPF heating during simultaneous operation
- auxiliary energies of the circulation pump of the KWT heat pump during heating are redistributed according to the fraction of simultaneous operation
- the storage losses in simultaneous operation are redistributed to the single and simultaneous mode according to the used energy fraction of combined operation in the bin
- the factor for the simultaneous operation is set to 0.6 to receive a combined operation of about 60% during the heating period according to the results of preliminary simulations, see chapter 4.7.2.

The calculation has been carried out for different system boundaries, as different statement can be concluded according to the system boundaries, which are used in different contexts. A detailed energy balance of the calculation and a summary for the single cases is given in the Appendix.

5.3.4 Generator seasonal performance factor of the two systems

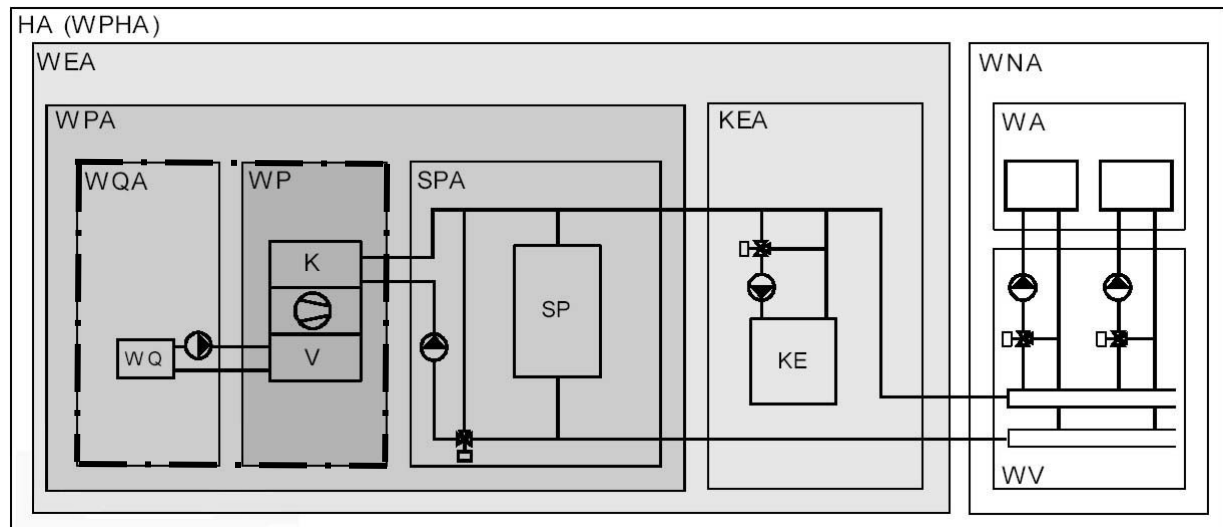

Fig. 29: system boundary for the seasonal performance factor generator (source RAVEL[13])

The generator seasonal performance factor describes the heat generator system, e.g. the heat pump. According to Fig. 29, where the system boundary for the generator seasonal performance factor is shown as dash-dotted line, the system boundary of the generator seasonal performance factor comprises the heat generator (WP) and the heat source (WQA), if applied for a heat pump system. This factor is used for the heat pump part of the generator system in prEN 14335.

Thus, the generator seasonal performance factor takes into account the produced heat of the heat pump, i.e. the used energy and the heat production to cover the storage losses and as expenses, the electricity input to the heat pump, which contains the same fractions as in the COP definition according to EN 255 (see eq. 10) and the additional external power for the source according to eq. 19. The generator seasonal performance can thus be calculated according to eq. 81

$$\text{SPF}_{\text{gen}} = \frac{Q_{\text{prod,h}} + Q_{\text{prod,DHW}}}{W_{\text{hp}} + W_{\text{aux,so,ext}}}$$

eq. 81

where

SPF_{gen} = seasonal performance factor of the generator

$Q_{\text{prod,h}}$ = produced heat energy of the heat pump in heating operation

$Q_{\text{prod,DHW}}$ = produced heat energy of the heat pump in DHW operation

W_{hp} = electricity input for the heat pump operation

$W_{\text{aux,so,ext}}$ = auxiliary electricity input for the source pump not included in the COP-values according to EN 255

Henceforth, only the energetic expense to operate the generator is considered, and thereby the capacity of the generator with an ideal attached system with no losses is described by this characteristic number.

The results of the calculation of the generator seasonal performance are shown in Tab. 26 for the KWT Swissline 40 NHB and in Tab. 27 for the Novelan SIC 9M. The results are compared to a gas boiler with a generator seasonal performance of $\eta_{\text{gen}} = 0.95$ based on the net calorific value and end energy.

Tab. 26: generator seasonal performance for the KWT Swissline 40 NHB (Refers to system boundary acc. to the RAVEL definition shown in Fig. 29 on page 87)

	KWT Swissline 40 NHB		Gas boiler*	
	Low-energy building acc. MINERGIE	Retrofit building	Low-energy building acc. MINERGIE	Retrofit building
Generator seasonal performance factor heating $SPF_{gen,h,hp}$	4.87	3.68	0.95	0.95
Generator seasonal performance factor DHW $SPF_{gen,DHW}$	2.02	2.19	0.95	0.95
Generator seasonal performance factor SPF_{gen}	3.50	3.32	0.95	0.95

*performance refers to net calorific value

Tab. 27: generator seasonal performance for the Novelan SIC 9M (Refers to system boundary acc. to the RAVEL definition shown in Fig. 29 on page 87)

	Novelan SIC 9M		Gas boiler*	
	Low-energy building acc. MINERGIE	Retrofit building	Low-energy building acc. MINERGIE	Retrofit building
Generator seasonal performance factor heating $SPF_{gen,h,hp}$	4.54	3.57	0.95	0.95
Generator seasonal performance factor DHW $SPF_{gen,DHW}$	2.75	2.75	0.95	0.95
Generator seasonal performance factor SPF_{gen}	3.83	3.40	0.95	0.95

*performance refers to net calorific value

The generator seasonal performance factor has in case of both systems SPF_{gen} -values that are significantly higher than 3, even in the retrofit case, where higher temperatures of the heating system are required. For the single heating operation the generator seasonal performance of the KWT system is almost 5.

Fig. 30 shows a comparison for the single and overall seasonal performance factors of the two systems for the low energy and the retrofit case, respectively. The KWT system has a better performance in the heating operation mode.

Because of the lower performance of the hot water part of the DHW operation, the overall generator seasonal performance of the KWT is a bit lower than in case of the Novelan system. The lower performance of the hot water part is caused on the one hand by the lower COP-characteristic shown in Tab. 16 to Tab. 20. On the other hand, the output capacity of the upper stage heat pump is lower, and by the longer running time the expenses for auxiliaries are increased, as well.

This difference becomes more obvious in the low-energy building case, while in the retrofit case the condensate subcooling effect is working more efficient due to higher supply

temperatures and the generator seasonal performance is almost equal. However, the Novelan system has still a higher performance factor of the DHW part in the retrofit case, which is almost cleared by the better performance of the heating part of the KWT system.

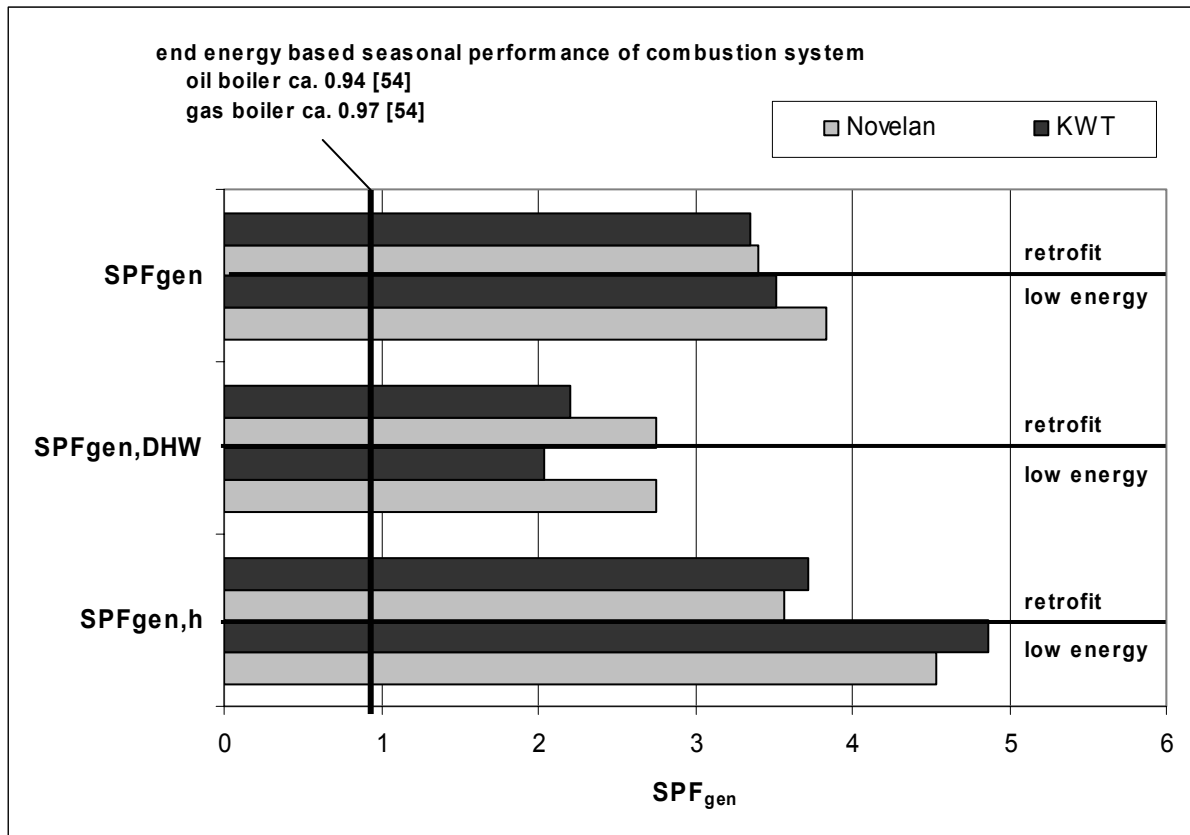

Fig. 30: comparison of the generator seasonal performance with combustion systems

5.3.4.1 Comparison with other heating systems

Fig. 30 shows as well the comparison to combustion heating systems (vertical line). The generator seasonal performance is often used to compare generators of heating systems. However, for a comparison of heating systems, it should always be carefully regarded, which system boundary is chosen to compare the systems and thus which energies are accounted to the system. Moreover it should be clear, which kind of energy is referred to, i.e. primary energy or used end energy. Here, the comparison is made on the basis of end energy produced by the generator and the system boundary according to Fig. 29. The comparison refers to single heating or DHW operation. The values in Fig. 30 demonstrate, that even at unfavourable conditions for the heat pump with high supply temperatures in the retrofit building and high domestic hot water temperatures, the seasonal performance of the heat pump is about 3.5 times better than the condensing gas boiler. This is remarkably, if it is taken into account, that the condensing gas boiler is the optimal boiler system with regard to performance available on the market. In the case of low temperature requirements of the heating system, i.e. in only heating mode with floor heating, the performance relation between the heat pump and the gas boiler reaches values of up to 5.

5.3.4.2 Comparison with DHW production by an electrical resistance heater

For the Novelan system and the low-energy building, another case was calculated, in which the domestic hot water production is done by an electrical resistance heater and the heat pump only supplies the heating energy. Results are shown in Tab. 28.

Tab. 28: Generator seasonal performance factors for space heating with Novelan heat pump and DHW with electric resistance heater in DHW storage

Heating: Novelan SIC 9M	Low-energy building
DHW: electrical resistance heater	
Generator seasonal performance factor heating	4.54
Generator seasonal performance factor DHW	1.00
Generator seasonal performance factor	2.26

The electrical resistance heater has a generator seasonal performance of 1.0. Consequently by the DHW production with the heat pump the performance is increased by a factor of 2.75, see Tab. 27. As the heating system is unchanged, the overall generator seasonal performance decreases by the worse performance of the electrical resistance heating from a value of 3.83 to a value of 2.26.

5.3.5 System seasonal performance factor according to RAVEL definition

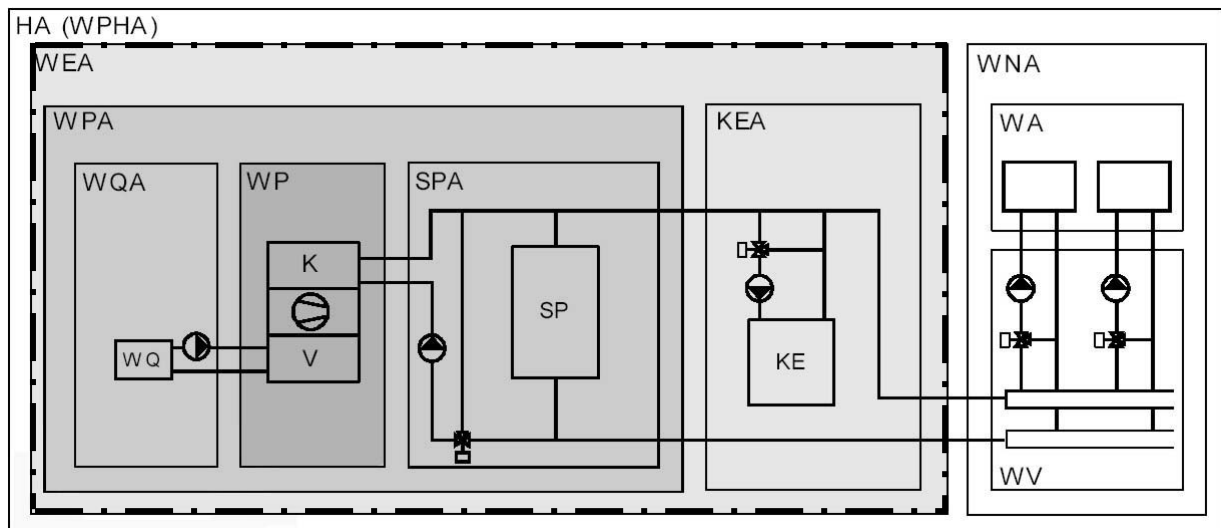

Fig. 31: system seasonal performance factor according to RAVEL definition

The system boundary for the system seasonal performance according to RAVEL definition corresponds to the system boundary “WEA” shown in Fig. 31. The system boundary thus comprises all system components up to the distribution of the heating and hot water system, i.e. the heat generator (or generators in case of bivalent systems) and potentially attached storage systems. Henceforth, the system seasonal performance factor refers to used energy, and system losses and expenses, i.e. storage losses and electricity input for auxiliaries are included in the system boundary and taken into account. Heat energies describe the net values available at the border of the heating system.

The results of the calculation for the system boundary according to the RAVEL definition shown in Fig. 31 are shown in Tab. 29 for the KWT Swissline 40 NHB and Tab. 30 for the Novelan SIC 9M. The results are compared to a gas boiler with a generator seasonal performance of $\eta_{\text{gen}} = 0.95$ based on the net calorific value.

Tab. 29: system seasonal performance acc. to RAVEL for the KWT Swissline 40 NHB
(Refers to system boundary acc. to the RAVEL definition shown in Fig. 31 on page 90)

	KWT Swissline 40 NHB		Gas boiler*	
	Low-energy building acc. MINERGIE	Retrofit building	Low-energy building acc. MINERGIE	Retrofit building
System seasonal performance factor heating acc. RAVEL	4.87	3.42	0.95	0.95
System seasonal performance factor DHW acc. RAVEL	1.60	1.73	0.74	0.74
System seasonal performance factor acc. RAVEL	3.30	3.03	0.89	0.92

*performance refers to net calorific value

Tab. 30: system seasonal performance acc. to RAVEL for the Novelan SIC 9M (Refers to system boundary acc. to the RAVEL definition shown in Fig. 31 on page 90)

	Novelan SIC 9M		Gas boiler*	
	Low-energy building acc. MINERGIE	Retrofit building	Low-energy building acc. MINERGIE	Retrofit building
System seasonal performance factor heating acc. RAVEL	4.54	3.37	0.95	0.95
System seasonal performance factor DHW acc. RAVEL	2.11	2.11	0.72	0.72
System seasonal performance factor acc. RAVEL	3.58	3.13	0.89	0.91

*performance refers to net calorific value

As no heating buffer storage is integrated in the low-energy building and the operation mode is monovalent, the system seasonal performance factor according to RAVEL corresponds to the generator seasonal performance factor. In the retrofit case, storage losses and expenses for the auxiliaries for the storage loading pump are taken into account contrary to the generator seasonal performance, and thus, the system seasonal performance acc. RAVEL decreases.

This decrease of the SPF due to storage losses becomes more obvious in the DHW operation, where a storage is installed in both the low energy and retrofit case and losses are higher than for the heating system due to higher temperature level and a longer operation period. System seasonal performance is hence remarkably reduced by the storage in comparison to the generator seasonal performance.

Both systems have a good system seasonal performance, as well. Even at higher supply temperatures of up to 55°C in the case of the retrofit building the overall seasonal

performance SPF_{RAVEL} is above 3. Like in the case of the SPF_{gen} the Novelan system has advantages for the domestic hot water operation, which becomes obvious in the low-energy building. Even though the KWT system has a better SPF for the heating operation and lower source pumping powers, the overall seasonal performance is lower in comparison to the Novelan system. In the retrofit case the difference between the two systems increases a bit in comparison to the generator seasonal performance, because the KWT has better COP-values for the heating operation, but lower output capacity, thus the running time in heating operation is longer for the KWT. In the RAVEL system boundary, the storage loading pump is taken into account, and thus the impact of the auxiliaries becomes more dominant.

The results are depicted in Fig. 32.

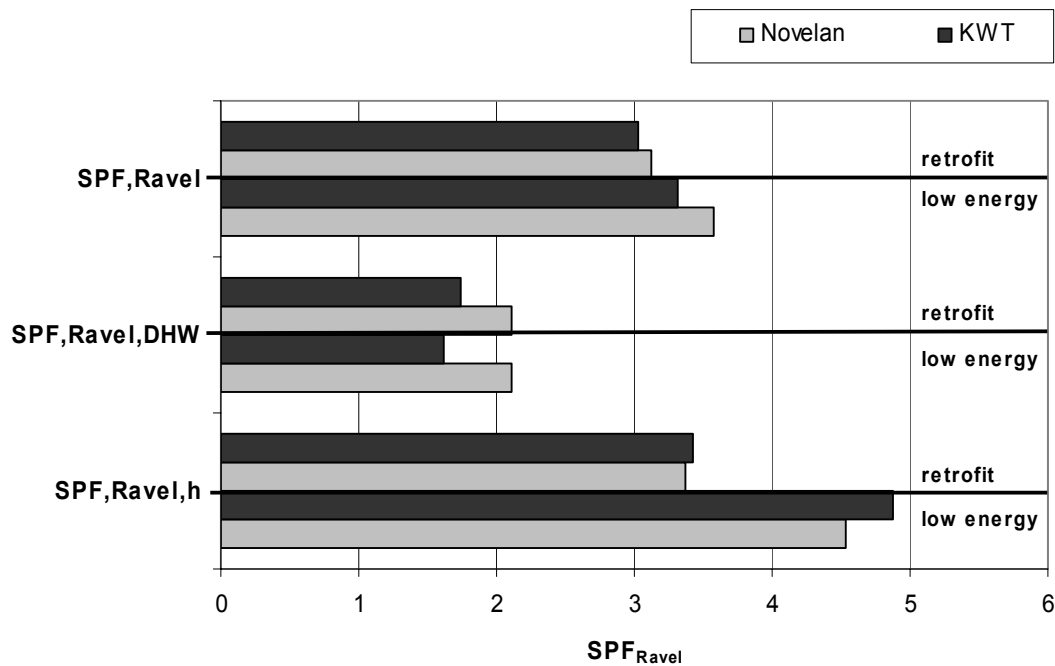

Fig. 32: comparison of the two systems according to the RAVEL system boundary

In the retrofit case the DHW operation of the KWT system becomes better because of the higher performance of the condensate subcooling at high supply temperatures of the heating system in simultaneous operation.

The values for single and simultaneous DHW operation of the KWT are depicted in Tab. 31.

Tab. 31: overall seasonal performance factors for DHW, KWT hot water heat pump (upper stage) in single and simultaneous operation

KWT Swissline 40 NHB		
	Low-energy building acc. MINERGIE	Retrofit building
System seasonal performance factor acc. RAVEL, DHW only operation	1.5	1.5
System seasonal performance factor acc. RAVEL, DHW simultaneous operation	2.00	2.35

Moreover electricity consumption to cover the storage losses decreases in combined operation (see Tab. 19 and Tab. 20), as the thermal losses stay constant and the COP increases. Nevertheless the seasonal performance does not reach the performance of the Novelan system, which is independent of the heating operation and thus stays constant for the low-energy and retrofit case.

The respective thermal system losses and expenses for auxiliaries according to the RAVEL system boundary are given in Tab. 32 and Tab. 33 for the Novelan SIC 9M and in Tab. 34 and Tab. 35 for the KWT Swissline 40 NTB.

Tab. 32: annual energies for the Novelan heat pump in the low-energy case

Novelan low energy		Heating	DHW
Storage losses buffer storage heating	kWh _{th}	-	-
Electricity input heat pump	kWh _e	2'017	892
Electricity input to cover DHW storage losses	kWh _e	-	456
Auxiliary energies	kWh _e	192	99
Electricity input back-up	kWh _e	-	-

Tab. 33: annual energies for the Novelan heat pump in the retrofit case

Novelan retrofit		Heating	DHW
Storage losses buffer storage heating	kWh _{th}	282	-
Electricity input heat pump	kWh _e	5'306	892
Electricity input to cover DHW storage losses	kWh _e	-	456
Auxiliary energies	kWh _e	560	99
Electricity input back-up	kWh _e	112	-

Tab. 34: annual energies for the KWT heat pump in the low energy case

KWT low energy		Heating	DHW
Storage losses buffer storage heating	kWh _{th}	-	-
Electricity input heat pump	kWh _e	1'923	1'156
Electricity input to cover DHW storage losses	kWh _e	-	465
Auxiliary energies	kWh _e	137	291
Electricity input back-up	kWh _e	-	-

Tab. 35: annual energies for the KWT heat pump in the retrofit case

KWT retrofit		Heating	DHW
Storage losses buffer storage heating	kWh _{th}	282	-
Electricity input heat pump	kWh _e	5'213	1'091
Electricity input to cover the storage losses	kWh _e	-	429
Auxiliary energies	kWh _e	486	247
Electricity input back-up	kWh _e	204	-

According to measurements and calculation approaches, for the heating operation, thermal storage losses are given, since the approach using the (U·A)-values of the storage is applied, while for the calculation of the domestic hot water operation, measurements according to EN 255-3 are used, which deliver the electricity input to cover the storage losses.

The Novelan system has a higher output capacity in the heating operation, and therefore less electricity input by the back-up system, as the balance point temperature is lower than in case of the KWT system. The higher auxiliary energy input of the Novelan system is caused by the higher source pumping power.

DHW operation shows the decreasing electricity input for storage losses in simultaneous operation at high temperatures in case of the KWT system, which is caused by increasing COP-values due to condensate subcooling. In the low energy case the KWT has higher electricity input to cover storage losses according to the measurements of WPZ Töss, see Tab. 17, Tab. 19 and Tab. 20 even though the storage is smaller.

The auxiliary input of the KWT system is higher than in case of the Novelan system, since the running time is longer because of the lower output capacity of the upper stage heat pump, even though the source pumping power itself is lower than for the Novelan system.

5.3.5.1 Impact of simultaneous operation

To assess the impact of combined operation SPF calculations for the theoretical fractions of combined operation of 1% and 99% have been made. Both cases are theoretically, since a fraction of 1% would mean, that a combined operation would be forbidden and the heating is switched-off in case of a hot water demand, which would lead to an alternate operation. A fraction of 99% would mean, that nearly all the possible running time in combined operation is used. This will not be the case in reality, as the shift in the heating and hot water demand will reduce the real combined operation. However, this can partly be optimised by the control system, see chapter 4.7.

Nevertheless, a combined running time of 99% does not mean, that during the heating period all the required energy for domestic hot water is produced in combined operation, as in spring and autumn the combined operation is limited by the operation time of the heating system. So parts of the domestic hot water demand have to be covered in single operation in this period, since the running time of the heating system is not sufficient. Preliminary simulations with an optimised controller result in fraction of combined operation of about 60%, as described in chapter 4.7.2. This value is used in the above calculation. Tab. 36 shows the SPF values for a fraction of 1% of combined operation and the respective values for a combined fraction of 99%.

Tab. 36: result for the KWT Swissline 40 NHB with 1% and 99% simultaneous operation

KWT Swissline 40 NHB	Low-energy building acc. MINERGIE		Retrofit building	
	1%	99%	1%	99%
Simultaneous operation				
System seasonal performance factor heating acc. RAVEL	4.87	4.87	3.42	3.42
System seasonal performance factor DHW acc. RAVEL	1.48	1.69	1.48	1.95
System seasonal performance factor according RAVEL	3.17	3.39	2.91	3.11

The potential for combined operation has under the given boundary conditions a limited impact on the overall efficiency of the system, as the heating is dominating the overall efficiency with respect to the energy amounts. However, the SPF for the hot water production increases significantly.

5.3.6 Overall system seasonal performance factor

The system boundary corresponds to the system boundary shown in Fig. 2. It is repeated in Fig. 33. The system boundary thus comprises all system components including the pumps of the heat distribution system. Henceforth, the system seasonal performance factor refers to used energy and all system losses and expenses, e.g. storage losses and electricity input for auxiliaries, are included.

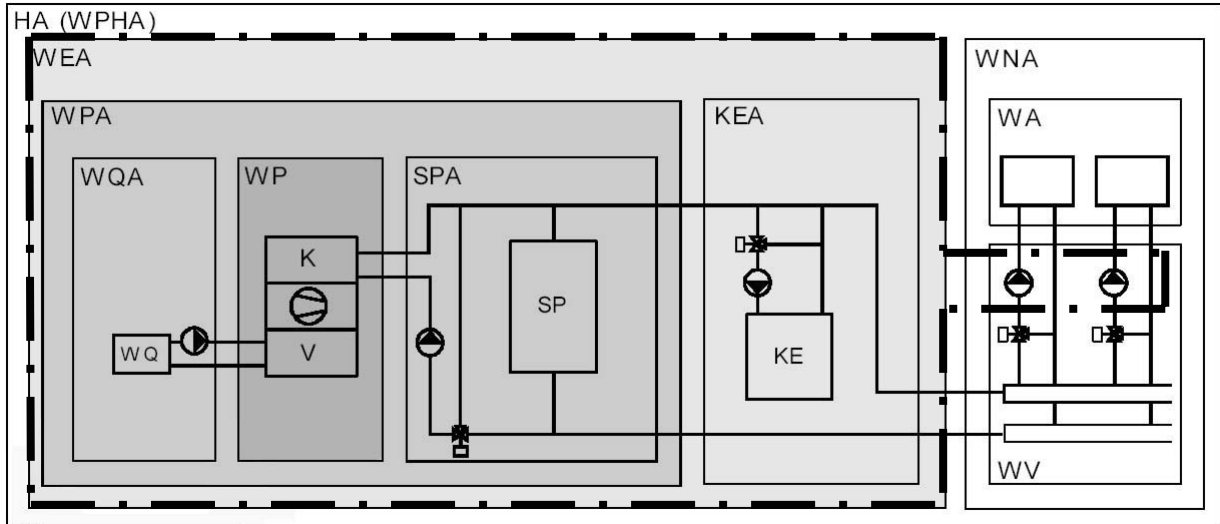

Fig. 33: System seasonal performance boundary

Heat energies describe the net values available behind the DHW storage or the heat distribution/emission system respectively. System boundaries, covering all energy flows to operate the system are taken into account, separated in thermal losses and electrical expenses.

The results of the calculation are shown in Tab. 37 for the KWT Swissline 40 NHB and in Tab. 38 for the Novelan SIC 9M. The values are depicted in Fig. 34. The results are compared to a gas boiler with a generator seasonal performance of $\eta_{gen} = 0.95$ based on the net calorific value.

The difference to the system boundary according to the RAVEL definition used in the last paragraph 5.3.5 is the integration of the circulation pump of the heating system into the system boundary

Tab. 37: result for the KWT Swissline 40 NHB (Refers to system boundary acc. to the RAVEL definition shown in Fig. 33 above)

	KWT Swissline 40 NHB		Gas boiler*	
	Low-energy building acc. MINERGIE	Retrofit building	Low-energy building acc. MINERGIE	Retrofit building
System seasonal performance factor heating	3.97	3.16	0.91	0.93
System seasonal performance factor DHW	1.60	1.73	0.74	0.74
System seasonal performance factor	2.95	2.85	0.86	0.90

*performance refers to net calorific value

Tab. 38: results for the Novelan SIC 9M (Refers to system boundary acc. to the RAVEL definition shown in Fig. 33, above)

	Novelan SIC 9M		Gasboiler*	
	Low-energy building acc. MINERGIE	Retrofit building	Low-energy building acc. MINERGIE	Retrofit building
Systems seasonal performance factor heating	3.76	3.14	0.91	0.93
Systems seasonal performance factor DHW	2.11	2.11	0.72	0.72
System seasonal performance factor	3.18	2.95	0.86	0.9

*performance refers to net calorific value

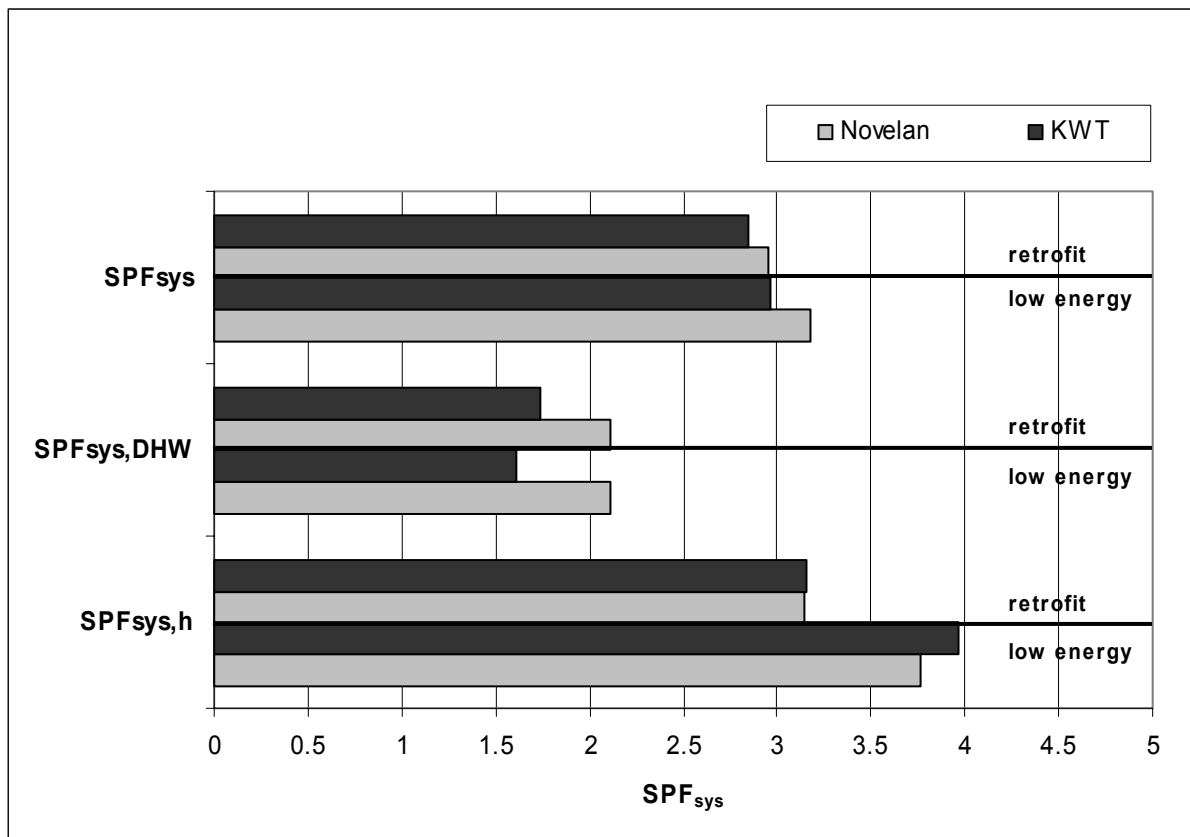

Fig. 34: Overall system seasonal performance acc. to the system factor

As the circulation pump in most of the actually available systems on the market normally runs through the entire heating period, the expenses for auxiliaries have an significant impact on the seasonal performance.

Tab. 39 shows the effects of the auxiliary energy requirements of the circulation pump on the system seasonal performance factor.

Tab. 39: Comparison of the auxiliary energy input according to the system boundary of RAVEL and overall SPF for the Novelan

	Low energy building acc. MINERGIE	Retrofit building
Auxiliary energy RAVEL	192	560
Auxiliary energy system	651	1006
Changes in SPF_h	0.87	0.23
Changes in SPF_{sys}	0.4	0.18

The circulation pump of the heating system causes a significant change in the system seasonal performance in comparison to the RAVEL system boundary. Thus the circulation pump should be dimensioned very carefully. Moreover the system seasonal performance could be increased remarkably, if other control strategies, which do not depend on a running circulation pump, are introduced.

5.3.7 Summary

Obviously the seasonal performance strongly depends on the system boundary and thereby the energies taken into account for the characteristic value, i.e. the seasonal performance factor. Thus in component or system comparison the system boundary has to be regarded closely. RAVEL defines the system boundary excluding the circulation pump of the heating system and thus delivers SPF_{sys} – values significantly higher than in the case of including the electricity input to all circulation pumps.

Another characteristic used is the generator seasonal performance factor, which defines the capacity of the generator with an ideal heating system attached, as no losses of the system are taken into account. This system boundary is often used to compare different heat generators, i.e. a boiler and a heat pump, as often only the fuel input of the boiler is taken into account.

However, the boiler itself has a requirement for auxiliary energy, as well, and there are further system losses and auxiliary expenses in boiler heating systems, too, until the used heating or domestic hot water energy is delivered to the user, and hence a system boundary which include all losses and auxiliary expenses will be used in standards like prEN 14335 [37]. It delivers the most comprehensive assessment of the seasonal performance, but is more complex to evaluate and it has to be taken care, that all systems are treated in an equal manner in the first step. Thus our standard proposal covers only the generator part.

With regard to the two systems the KWT has advantages in the performance of the heating operation, while the Novelan system has a better DHW operation. Under the given boundary conditions, the lower DHW performance of the KWT system leads to lower overall seasonal performance factors. This effect is the stronger, the larger the system boundary is set, as auxiliary consumption has an impact due to the running time.

If the COP-characteristic of the upper stage in single DHW operation and the auxiliary consumption could be improved, the concept of the condensate subcooling will probably turn out to be advantageous to the alternate operation. In the actual configuration, the advantages of simultaneous operation are overcompensated by the lower performance in single operation and the higher auxiliary consumption. Already in the existing configuration, the seasonal performance in simultaneous operation increases notably. However the impact of simultaneous operation depends basically on the temperature level of the heating system and thus has stronger impact in the retrofit application field.

6 CONCLUSIONS

On the basis of existing calculation methods documented in international standardisation or technical guidelines/handbooks a calculation method for the seasonal performance factor of heat pumps for combined heating and domestic hot water production based on different system boundaries has been developed. The method is as well applicable to single heating and hot water heat pumps. As all existing methods seemed limited in some respect (e.g. no domestic hot water calculation, only monovalent operation etc.) the FHBB method based on the wide spread bin method has been developed, which considers the following physical effects:

- Meteorological influences of the ambient dry bulb temperature of the site
- Impact of sink and source temperature on the COP and output capacity
- Losses due to cyclic operation
- Storage losses of both heating and hot water storages integrated in the system
- Additional auxiliary energies supplied to source and sink pumps
- Monoenergetic operation for three operation modes (partly parallel, parallel, alternate)

To consider the simultaneous operation an approach of energetic weighting with the respective energy demand fraction in single and combined mode has been integrated. The energetic fraction of the combined and the single operation are estimated by the respective energy requirements and the output capacities of the heat pump.

As control and tapping profiles of the demand have an impact on the duration of combined operation, as well, a correction factor has been introduced. Preliminary simulations show, that an enhanced control system, which takes into account the operation state of the heating system increases the simultaneous operation from about 30% to 60% with respect to a simple two point hysteresis control, which does not consider the state of the heating system.

For the single heating mode the method was compared to simulations taken from the STASCH project [19]. It showed an accordance up to about 6-7%, which slightly depends on the system configuration. This can be explained on the one hand with uncertainties in the approaches applied (e.g. cyclic operation), on the other hand certain aspects cannot be considered exactly, e.g. impact of the control system.

Another strong impact on the calculation is the availability of input data. The performance of the heat pump has been evaluated from standard testing according to existing standards. Concerning simultaneous operating systems, the existing European standards do not deliver sufficient information. That is why a test procedure based on the existing European standards has been developed in the Swiss national test centre WPZ Töss, which is documented in [7]. A summary of the methods is given in chapter 4.6. However, the method is still time consuming and therefore cost-expensive. Reasons are the existing standards, in particular the test cycle according to EN 255-3, which in total lasts about 4 days for one point of the heat pump characteristic. To evaluate the heat pump characteristic for different operation conditions, which is essential for the SPF calculation, more testing points are useful, i.e. the testing expenses would be tremendous.

Moreover dynamic testing of the heat pump to characterise cyclic operation does not exist in European standardisation, either. In Switzerland, a test procedure has been developed which is described in [12] and [14]. On the basis of the characteristics given by this method an approach for cyclic operation has been integrated.

As far as possible, analytical approaches have been chosen. However, in the case of cyclic

operation and the influence of control on simultaneous operation results of simulations have been used to derive correction factors. These approaches should be investigated in more detail to either derive analytical approaches or confirm the approaches statistically or empirically.

Based on the measured characteristics in [7] seasonal performance calculation for the two measured systems for different system boundaries have been made.

The comparison of the two heat pump systems to each other shows, that the KWT has advantages concerning the heating performance both in the low energy as in the retrofit case. However, the Novelan heat pump shows a better seasonal performance of the hot water part, which can be explained by two facts:

On the one hand, the measured characteristic of the upper stage heat pump of the KWT system is lower than the measured characteristic of the Novelan system, on the other hand, the output capacity of the KWT upper stage heat pump is lower and thereby the running time of the upper stage heat pump is increased. This effect is only partly compensated by a longer combined operation and better performance due to the condensate subcooling. The higher auxiliary consumption by the longer running time of the KWT system has a stronger impact on the seasonal performance.

Thus concerning the overall efficiency the alternate operating system has advantages under the considered boundary conditions, as the better heating performance of the simultaneous operating system cannot compensate the lower performance of the hot water part.

Compared to other heating systems on the basis of the system boundary of the generator seasonal performance and concerning end energy both heat pump systems have obvious advantages. The heat pump seasonal performance in heating operation surpasses the performance of the better of the combustion systems, the condensing gas boiler, by a factor higher than 4.

For a single DHW application, the relation of the seasonal performance factors between the heat pump and an electric resistance water heater is 2.75 on the basis of the system boundary of the generator seasonal performance.

Consequently the domestic hot water production by heat pumps in combined operation has a significant better seasonal performance in comparison to other heat generator systems on the market and efforts to achieve a higher market share can contribute to environmentally relevant energy savings.

7 ACKNOWLEDGEMENTS

The authors like to thank the following persons and institutions involved in this project:

Dr. Martin Zogg and Prof. Dr. Thomas Kopp (both project advisors and head of the research programme at SFOE) for the contracting and advising in the project.

Special thanks have to be expressed to A. Montani, the project manager of the parallel project for the development of the test procedure at WPZ Töss, for the useful and constructive discussion and hints as well as the good cooperation in the parallel project at WPZ Töss.

H. Reiner (Novelan) and D. Trüssel (KWT) for the provision of the two investigated systems.

Prof. G. Zweifel for the accompanying and advising in the project.

Colleagues and collaborators at the Institute of Energy for their help in this project.

8 NOMENCLATURE

Variables

The nomenclature is derived from prEN 12831 and prEN14335

A	area, surface	m ²
c	specific heat capacity	J/(kgK)
f	correction factor	-
n	number of quantity (e.g. cycles, hours .etc.)	-
P	electrical power	W
Q	quantity of heat, energy	J
t	time, period of time	s
T	thermodynamic temperature	K
U	heat loss coefficient (U-value)	W/(m ² ·K)
\dot{V}	volumetric flow rate	m ³ /s
W	electrical energy	J
w	weighting factor	-
Θ	Celsius temperature	°C
Δp	pressure drop	Pa
α	relative operation time	-
β	relation of switch on time constant to cycle time of the heat pump	-
γ	relation time constants of heat pump	-
ε	efficiency factor	-
φ	thermal power	W
η	efficiency	-
ρ	density	kg/m ³
τ	time constant of the heat pump	s

Indices

amb	ambient
aux	auxiliary
av	average
bl	building (demand)
bp	balance point
bu	back-up
C	Carnot
car	carter
cold	cold process side

Indices (continued)

com	compressor
combi	combined operation
con	condenser
ctrl	control
cw	cold water temperature to hot water storage
cyc	cyclic
δ	(energetic) fraction
DHW	domestic hot water
dyn	dynamic
eff	effective
EN 255-2	refers to EN 255-2
EN 255-3	refers to EN 255-3
end	end of consideration
env	environment
eva	evaporator
ex	exergetic
ext	external
gen	generator
h	heating
HDH	heating degree hours
hot	hot process side
hours	hours
hp	heat pump
hw	tapped hot water temperature
i	refers to bin i
ID	indoor at design condition
in	input to system; inlet
int	internal
l	loss
lower	lower limit
ltc	lower temperature cutout
max	maximum
OD	outdoor at design condition
off	standstill
on	running
op	operation
out	output from system; outlet
phase 2	refers to phase 2 of EN 255-3 cycle
phase 4	refers to phase 4 of EN 255-3 cycle

Indices (continued)

prod	Energy produced by the heat pump (used energy and storage losses)
ref	reference value
r	return temperature
s	storage
si	sink
sin	single
so	source
ss	steady-state
standard	referring to standard testing point
sys	system
t	total
T	temperature
t _{OD}	outdoor design temperature
ulh	upper limit for heating
upper	upper limit
used	used fraction of energy
w	water

Specific Nomenclature from other standards:

Nomenclature from ASHRAE

δ	factor to consider fraction of back-up heating operation	-
Θ	time	h
Θ_{cyc}	duration of time for one complete cycle consisting of one compressor ON time and one compressor OFF time	h
BL	building load	Btu/h/1000
C _D	cyclic degradation coefficient	-
COP _{cyc}	cyclic coefficient of performance	W/W
COP _{ss}	COP from steady state high temperature test	W/W
c _{pa}	specific heat of air	Btu/lb·°F
CPF _{hs}	combined performance factor	-
DHR	design heating requirement	Btu/h
E	Electrical energy input to heating	Wh
\dot{E}	electrical power input	W
E _{cyc}	total electrical energy used in cyclic test	W
ER	electrical input to resistance water heater	W
F _{def}	factor for correction of defrost losses	-

Nomenclature from ASHRAE (continued)

HSPF	heating seasonal performance factor	-
N	Total number of hours in a given season	h
n_j	fractional bin hours	-
PLF	part load factor	-
q	total space conditioning provided	Btu
q'_{cyc}	net integrated capacity	Btu
q_{cyc}	total integrated capacity (indoor-side data) for dry-coil cycling test	Btu
q_w	hot water energy	Btu
\dot{q}_{thi}	total heating capacity, indoor side data	Btu/h
Q_{mi}	air flow, indoor, measured	cfm
RH	resistance heating	kW
t_{a1}	air temperature, entering indoor side, dry-bulb	°F
t_{a2}	air temperature, leaving outdoor side	°F
t_j	temperature of bin j	°F
t_{OD}	outdoor design temperature	°F
v_n'	specific volume air at nozzle	ft ³ /lb
W_n	humidity ratio	lb moisture/lb dry air

Nomenclature from EN 255-3

COP_t	COP for the extraction of hot water according to EN 255-3	-
P_{es}	electrical energy input to cover storage losses	W
Q_t	heat energy extracted with the domestic hot water during phase 2 of EN 255-3	kWh
t_s	stand-by time in phase 4	s
t_t	time for the one cycle in phase 2 of EN 255-3 (extraction of DHW and heating-up)	s
W_{es}	electricity input during phase 4 of EN 255-3	kWh
W_t	electricity input during phase 2 of EN 255-3	kWh

Nomenclature from VDI 2067-6

b_{DHW}	full load hours for DHW operation	h/a
b_h	full load hours for heating operation	h/a
F_i	full load hours	h/a
G_t	Average heating degree days at site of system	(K·d)/a
Z_t	cumulated number of hours	h/a
t_a	ambient dry bulb air temperature	°C

Nomenclature from VDI 2067 (continued)

t_i	design indoor temperature	°C
t_i'	fictive design indoor temperature	°C
t_N	design outdoor temperature	°C
β	Seasonal performance factor	-
ε	efficiency factor	-

Abbreviations

ARI – Air conditioning and Refrigeration Institute

ASHRAE – American Society of Heating, Refrigerating and Air conditioning Engineers Inc.

COP – coefficient of performance

DHW – domestic hot water

DIN – Deutsches Institut für Normung (German institute of standardisation)

EN – Europäische Norm (European Standard)

FHBB – Fachhochschule Beider Basel (University of Applied Sciences Basel)

HA (WPHA) – (Wärmepumpen-)Heizanlage ((heat pump) heating system)

HP – heat pump

KEA - back-up system

OP – operation point

SIA – Schweizerischer Ingenieur- und Architektenverband (Swiss association of engineer and architects)

SPA - storage system

SPF – seasonal performance factor

SFOE – Swiss Federal Office of Energy

STASCH – Standardschaltungen (standard hydraulic circuits)

VDI – Verein deutscher Ingenieure (German association of engineers)

VSSH - Vereinigung der Schweizerischen Sanitär und Heizungsfachleute (Swiss sanitary and heating experts association)

WA – Wärmeabgabesystem (heat emission system)

WEA – Wärmeerzeugungssystem (heat generation system (heat pump system and back-up)

WNA – Wärmenutzungssystem (heat utilisation system (heat distribution and heat emission))

WP – Wärmepumpe (heat pump)

WPA – Wärmepumpenanlage (heat pump system)

WPZ – Wärmepumpentestzentrum (Swiss heat pump test centre at Winterthur – Töss)

WQA – Wärmequellenanlage (heat pump source system)

WV – Wärmeverteilsystem (heat distribution system)

9 REFERENCES

- [1] VDI Richtlinie 2067, Kostenberechnung für Heizanlagen, Blatt 6, Wärmepumpen, Kurzverfahren, VDI-Verlag, Düsseldorf, 1989
- [2] VDI Richtlinie 4650, Blatt 1, Berechnung von Wärmepumpen, Kurzverfahren zur Berechnung der Jahresaufwandszahlen von Wärmepumpenanlagen, Elektro-Wärmepumpen zur Raumheizung, VDI Verlag, Düsseldorf, November 2000
- [3] VDI Richtlinie 2067, Kostenberechnung für Heizanlagen, Blatt 6, Wärmepumpen, Langverfahren, VDI-Verlag, Düsseldorf, 1986
- [4] Th. Afjei, G. Zweifel, M. Wetter et al.: Kostengünstige Niedertemperaturheizung mit Wärmepumpe, Technisches Handbuch, darin: Handrechenmethode zur Bestimmung der Jahresarbeitszahl von Wärmepumpenanlagen für Heiz- und Warmwasserbetrieb SFOE research program heat pumping technologies, cogeneration, refrigeration, 1997 (download available on the website of the research programme www.waermepumpe.ch/fe/projekte/nth) (download from the website of the research programme www.waermepumpe.ch/fe/nth category "Berichte")
- [5] C. Feldmann: Methods for calculation of system energy requirement and system efficiency, Working Paper N 259 of CEN/TC 228/WG 4, 2002
- [6] ANSI/ASHRAE standard 116-1995: Methods of testing for rating seasonal efficiency of unitary air conditioners and heat pumps, American society of Heating, Refrigerating and Air conditioning Engineers, inc., Atlanta 1995
- [7] A. Montani: Wärmepumpentest für die kombinierte Raumheizung und Warmwasseraufbereitung, final report in German, SFOE research program heat pumping technologies, cogeneration, refrigeration, 2003 (download available on the website of the research programme www.waermepumpe.ch/fe category "Berichte"),
- [8] SIA 380/1:2001, Thermische Energie im Hochbau, 2001, Schweizerischer Ingenieur und Architektenverein
- [9] SIA 384/2, Wärmeleistungsbedarf von Gebäuden, 2001, Schweizerischer Ingenieur und Architektenverein
- [10] Software Meteororm, Version 4.0, Meteotest, 2002
- [11] WPZ Bulletin, Wärmepumpen-Testzentrum Töss, November 2002, (download available on <http://www.wpz.ch>)
- [12] E. Shafai, D. Zogg, M. Ehrbar, L. Wirth: Dynamischer Wärmepumpentest, Phase 1-3, Etappe 3, Modellansatz für die prüftechnische Charakterisierung der Minderwärmeproduktion, final report in German, SFOE research program heat pumping technologies, cogeneration, refrigeration, 2001 (download available on the website of the research programme www.waermepumpe.ch/fe category "Berichte"),
- [13] Wärmepumpen – Planung, Bau und Betrieb von Elektrowärmepumpenanlagen, RAVEL im Wärmesektor Heft 3, Bundesamt für Konjunkturfragen, 1996
- [14] M. Ehrbar, B. Hubacher: Dynamischer Wärmepumpentest, Phase 2 Validierung des Modellansatzes und Entwicklung einer Prüfprozedur, final report in German, SFOE research program heat pumping technologies, cogeneration, refrigeration, 2002 (download available on the website of the research programme www.waermepumpe.ch/fe category "Berichte")

- [15] M. Ehrbar, B. Hubacher: Verbesserung des Abtauens bei luftbeaufschlagten Verdampfern, final report in German, SFOE research program heat pumping technologies, cogeneration, refrigeration, 2000
(download available on the website of the research programme www.waermepumpe.ch/fe category "Berichte"),
- [16] EN 255-2: Air conditioners, liquid chilling packages and heat pumps with electrically driven compressors – Heating mode – Part 2: Testing and requirements for marking for space heating units, SN EN 255-2:1997
- [17] EN 255-3: Air conditioners, liquid chilling packages and heat pumps with electrically driven compressors – Heating mode – Part 3: Testing and requirements for marking for sanitary hot water units, SN EN 255-3:1997
- [18] T. Afjei et al: Standardschaltungen für Kleinwärmepumpen, planning guide (part 1) report in German or French, SFOE research program heat pumping technologies, cogeneration, refrigeration, 2002
(download available on the website of the research programme www.waermepumpe.ch/fe category "Berichte")
- [19] T. Afjei et al: Standardschaltungen für Kleinwärmepumpen, fundamentals and computer simulations (part 2) report in German, SFOE research program heat pumping technologies, cogeneration, refrigeration, 2002
(download available on the website of the research programme www.waermepumpe.ch/fe category "Berichte")
- [20] SIA 381/3:1982, Heizgradtage der Schweiz, 1982, Schweizerischer Ingenieur und Architektenverein
- [21] H.R. Gabathuler, H. Mayer: Messungen an Retrofit Wärmepumpen, final report in German, SFOE research program heat pumping technologies, cogeneration, refrigeration, 2002
(download available on the website of the research programme www.waermepumpe.ch/fe category "Berichte")
- [22] Heikrodt, Hafner: Vergleich von erdgas- und elektrisch betriebenen Wärmepumpen für die Hausheizung, DKV Deutsche Kälte-Klima Tagung 2001
- [23] DIN 4702, Teil 8, Heizkessel, Ermittlung des Normnutzungsgrades und der Norm-Emissionsfaktoren, Beuth Verlag, März 1990
- [24] ARI Standard 210/240, Unitary air conditioning and air source heat pump equipment, Air conditioning and Refrigeration Institute, 1994
- [25] Jacques Bernier, Pompes à chaleur: impact du fonctionnement à charge partielle sur le rendement, p. 68- 73, Chaud, Froid, Plomberie N° 650, October 2002
- [26] B. Hinder, M. Ehrbar, Prüfreglement für die Prüfung von Luft-/Wasser Wärmepumpen auf die Prüfstand Töss, 2. Revision vom 3. Oktober 1996
- [27] A. Huber: Berechnungsmodul für Erdwärmesonden, final report in German, SFOE research program heat pumping technologies, cogeneration, refrigeration, 1997
- [28] W.Leu, B.Keller, Th.Mégel et al: PC-Programm für geothermische Eigenschaften des Schweizer Molassebeckens - User's Manual of the program SwEWS, final report in German, SFOE research program heat pumping technologies, cogeneration, refrigeration, 1999
(download available on the website of the research programme www.waermepumpe.ch/fe category "Berichte")

- [29] SIA 385/3, Warmwasserversorgungen für Trinkwasser in Gebäuden, Ingenieur- und Architektenverein, 1991, CH
- [30] VSSH, Handbuch Vereinigung Schweizer Sanitär- und Heizungsfachleute, Burgdorf, 1998
- [31] IEA HPP Annex 28: test procedure and seasonal performance calculation of residential heat pumps with combined space and domestic hot water production, legal text, International Energy Agency, 2003
- [32] CEN/TC 113 N 366, Draft prTS (WI 00113024), 2002
- [33] EN 12976-2 thermal solar systems and components – Factory made systems – Part 2 Test methods
- [34] ENV 12977-2:2001, Thermal solar systems and components - Custom built systems - Part 2: Test methods.
- [35] DIN V 4701 –part 10:2001 Energy efficiency of heating and ventilation systems in buildings - Part 10 heating, domestic hot water, ventilation
- [36] DIN V 4108-6:2003 Thermal protection and energy economy in buildings - Part 6: Calculation of annual heat and annual energy use
- [37] prEN 14335: 2002 Heating systems in buildings method for calculation of system energy requirements and system efficiencies part 2: Heat Generation – heat pump systems
- [38] Zogg, Einführung in die Wärmepumpentechnik, Kursteil Wärmepumpen der Schweizerischen Vereinigung für Geothermie, Fassung 2003; , (download available http://www.treffpunkt-kaelte.de/kaelte/de/html/grundlagen/zogg_wp.pdf)
- [39] H.C. Peitsmann, H. J. Nicolaas IEA Annex 10 „Liquid Chilling systems“, 1988, TNO Institute of applied physics, The Netherlands, 1988
- [40] prEN12831:2002, Heating systems in buildings, method for the calculation of the design heat load
- [41] EN 832:1998 Thermal performance of buildings calculation of energy use for heating residential buildings
- [42] DIN V 4753:1996 Water heaters and water heating installations for drinking water and for services – Part 8: Thermal insulation for water heaters with nominal capacity up to 1000 l – Requirements and testing
- [43] TC 113 WI 00113027:2002 (draft of prEN14551) Air conditioners, liquid chilling packages and heat pumps with electrically driven compressors for space heating and cooling – Part 2: test conditions
- [44] NT VVS 086. Exhaust air heat pumps: performance, Nordtest method, 1990
- [45] SMS, 1986 SS 2095: heating equipment – laboratory testing of heat pumps, Swedish Mechanical Standards Institution, Stockholm
- [46] SP Method 0023: A standardised method for defining the performance of heat pumps, Swedish National Testing and Research Institute, Borås

- [47] ASHRAE standard 137-1995: Methods for testing for Efficiency of Space-Conditioning/Water Heater Appliances that include a Desuperheater water heater, American society of Heating, Refrigerating and Air conditioning Engineers, inc. Atlanta 1995
- [48] ASHRAE standard 124-1991: Methods of Testing for Rating Combination Space Heating and Water Heating Appliances, American society of Heating, Refrigerating and Air conditioning Engineers, inc. Atlanta 1991
- [49] W. Eugster, Polydynamics Engineering Zürich, aus Bericht Kostengünstige Niedrigtemperaturheizung mit Wärmepumpe: Phase 1 Machbarkeitsanalyse, Problemanalyse und Vorbereitung zum Bau eines Funktionsmusters. Forschungsprogramm Umgebungs-und Abwärme, Wärmekraftkopplung (UAW). Bundesamt für Energie (BFE), Bern, 1996
- [50] T. Afjei et al, Kostengünstige Niedertemperaturheizung mit Wärmepumpe, Phase 3: Messungen an drei Funktionsmustern, Benutzereinfluss, Vergleich verschiedener Heiz- und Regelkonzepte, final report in German, SFOE research program heat pumping technologies, cogeneration, refrigeration, 2000
(download available on the website of the research program www.waermepumpe.ch/fe category "Berichte")
- [51] Schweizer Energieverordnung (EnV) 730.01, Schweizer Bundesrat, january 2002
- [52] Technical data sheet of the Novelan SIC 9M, manufacturer data, Siemens heating technologies, 2002
- [53] Mandate to CEN and CENELEC (2002) for the elaboration and adoption of measurement standards for household appliances: Water heaters, hot water storage appliances and water heating systems', TREN D1 D(2002), Brussels
- [54] R. Frischknecht, P. Suter, R. Dones et al., Ökoinventare von Energiesystemen“, Gruppe Energie, Stoff, Umwelt (ESU), ETH Zürich und PSI, Villingen, 3. Auflage, Juli 1996
- [55] prEN 13203, Qualification of domestic hot water function of gas-fired appliances for domestic use

10 APPENDIX

Project name

KWT_Neubau.xls

parameter**unit****values****Input data Building**

Generation load at design outdoor temperature heating requirement	kW	5		
Domestic hot water requirement	kWh/a	10039		
Share of hot water energy demand	kWh/a	3053		
cold water temperature	%	23.3		
hot water tap temperature	°C	15		
hot water temperature generated with the heat pump	°C	55		

Meteorological data

meteorological site		Zurich SMA		
design outdoor temperature	°C			-11

Parameter heating system**EN 255-2**

heating capacity at	W	B0/W35	B0/W50	
Electrical power input at	W	9015	8604	
COP at	-	2021	2917	
		4.46	2.95	

Storage heat loss (U*A-value) heating

EN 255-3

output capacity domestic hot water	W	B0/*	B0/W35	B0/W50
COP _i for the extraction of domestic hot water	-	1141	1751	2133
		2.36	2.70	3.38

heating curve

supply temperature at upper temperature limit for heating	°C	outdoor	supply	
supply temperature at outdoor design temperature	°C	15.0	25.2	
		-11.0	35.0	

Blocking time per day [h/d]	h/d	3		
-----------------------------	-----	---	--	--

electricity input

rated power of source pump	W	150		
rated power of sink pump	W	90		
rated power of storage pump for heating buffer	W	0		
rated power of storage pump for DHW storage	W	0		

electricity power input to cover storage losses DHW		B0/*	B0/W35	B0/W50
		62.4	36.3	29.3

Calculation results**System**

Overall Seasonal Performance Factor SPF_{sys}	-	2.95		
Seasonal Performance Factor heating $SPF_{sys,h}$	-	3.97		
Seasonal Performance Factor domestic hot water $SPF_{sys,DHW}$	-	1.60		

electricity consumption

Total electricity consumption	kWh	4442		
fraction for back-up heating	%	0.0		
fraction for back-up domestic hot water	%	0.0		
fraction for auxiliaries	%	20.2		
electricity input to cover storage losses	%	10.5		

Storage losses

Storage losses heating buffer		0		
share of storage losses heating buffer	%	0.0		
Storage losses DHW		811		
share of storage losses DHW	%	21.0		

Generator

Overall seasonal performance factor SPF_{gen}		3.50		
seasonal performance factor heating $SPF_{gen,h}$		4.87		
seasonal performance factor DHW $SPF_{gen,DHW}$		2.02		

Project name

KWT_Retrofit.xls

parameter**unit** **values****Input data Building**

Generation load at design outdoor temperature heating requirement	kW	8.8		
Domestic hot water requirement	kWh/a	20158		
Share of hot water energy demand	kWh/a	3053		
cold water temperature	%	13.2		
hot water tap temperature	°C	15		
hot water temperature generated with the heat pump	°C	55		

Meteorological data

meteorological site		Zurich SMA		
design outdoor temperature	°C	-11		

Parameter heating system**EN 255-2**

heating capacity at	W	B0/W35	B0/W50	
Electrical power input at	W	9015	8604	
COP at	-	2072	2868	
		4.35	3.00	

EN 255-3

output capacity domestic hot water	W	B0/*	B0/W35	B0/W50
COP _i for the extracton of domestic hot water	-	1141	1751	2133
		2.36	2.70	3.38

Storage heat loss (U*A)-value) heating	W/K	2.40		
--	-----	------	--	--

heating curve

supply temperature at upper temperature limit for heating	°C	outdoor	supply	
supply temperature at outdoor design temperature	°C	15	28.7	
		-11	55.0	

Blocking time per day [h/d]	h/d	3		
-----------------------------	-----	---	--	--

electrical input

rated power of source pump	W	150		
rated power of sink pump	W	90		
rated power of storage pump for heating buffer	W	90		
rated power of storage pump for DHW storage	W	0		
		B0/*	B0/W35	B0/W50
Electricity power input to cover storage losses	W	62.4	36.3	29.3

Calculation results**System**

Overall Seasonal Performance Factor SPF_{sys}	-	2.85		
Seasonal Performance Factor heating $SPF_{sys,h}$	-	3.16		
Seasonal Performance Factor domestic hot water $SPF_{sys,DHW}$	-	1.73		

electricity consumption

Total electricity consumption	kWh	8139		
fraction for back-up heating	%	0.0		
fraction for back-up domestic hot water	%	0.0		
fraction for auxiliaries	%	14.8		
electricity input to cover storage losses	%	5.3		

Storage losses

Storage losses heating buffer		282		
share of storage losses heating buffer	%	1.4		
Storage losses DHW		811		
share of storage losses DHW	%	21.0		

Generator

Overall seasonal performance factor SPF_{gen}		3.32		
seasonal performance factor heating $SPF_{gen,h}$		3.68		
seasonal performance factor DHW $SPF_{gen,DHW}$		2.19		

Project name	Novelan_Neubau.xls		
parameter	unit	values	
Input data Building			
Generation load at design outdoor temperature	kW	5	
heating requirement	kWh/a	10039	
Domestic hot water requirement	kWh/a	3053	
Share of hot water energy demand	%	23.3	
cold water temperature	°C	15	
hot water tap temperature	°C	55	
hot water temperature generated with the heat pump	°C	55	
Meteorological data			
meteorological site		Zurich SMA	
design outdoor temperature	°C	-11	
Parameter heating system			
EN 255-2		B0/W35	B0/W50
heating capacity	W	9477	9282
Electrical power input	W	2179	3094
COP	-	4.35	3.00
EN 255-3		B0/*	
output capacity domestic hot water	W	7069	
COP _i for the extraction of domestic hot water	-	3.06	
Storage heat loss (U*A)-value) heating	W/K	0.00	
heating curve			
supply temperature at upper temperature limit for heating	°C	outdoor	supply
supply temperature at outdoor design temperature	°C	15	25.2
		-11	35.0
Blocking time per day [h/d]	h/d	3	
electrical input			
rated power of source pump	W	245	
rated power of sink pump	W	90	
rated power of storage pump for heating buffer	W	0	
rated power of storage pump for DHW storage	W	90	
Calculation results			
System			
Overall Seasonal Performance Factor SPF _{sys}	-	3.18	
Seasonal Performance Factor heating SPF _{sys,h}	-	3.76	
Seasonal Performance Factor domestic hot water SPF _{sys,DHW}	-	2.11	
electricity consumption			
Total electricity consumption	kWh	4117	
fraction for back-up heating	%	0.0	
fraction for back-up domestic hot water	%	0.0	
fraction for auxiliaries	%	18.2	
electricity input to cover storage losses	%	11	
Storage losses			
Storage losses heating buffer		0	
share of storage losses heating buffer	%	0.0	
Storage losses DHW		927	
share of storage losses DHW	%	23.3	
Generator			
Overall seasonal performance factor SPF _{gen}		3.83	
seasonal performance factor heating SPF _{gen,h}		4.54	
seasonal performance factor SPF _{gen,DHW}		2.75	

Project name

Novelan_Retrofit.xls

parameter**unit****values****Input data Building**

Generation load at design outdoor temperature heating requirement	kW	8.8
Domestic hot water requirement	kWh/a	20158
Share of hot water energy demand	kWh/a	3053
cold water temperature	%	13.2
hot water tap temperature	°C	15
hot water temperature generated with the heat pump	°C	55

Meteorological data

meteorological site		Zurich SMA
design outdoor temperature	°C	-11

Parameter heating system**B0/W35****B0/W50****EN 255-2**

heating capacity at	W	9477	9282
Electrical power input at	W	2179	3094
COP at	-	4.35	3.00

EN 255-3**B0/***

output capacity domestic hot water	W	7069
COPT for the extraction of domestic hot water	-	3.06

Storage heat loss (U*A)-value) heating	W/K	2.40
Storage heat loss (U*A-value) domestic hot water	W/K	0.00

heating curve**outdoor****supply**

supply temperature at upper temperature limit for heating	°C	15	28.7
supply temperature at outdoor design temperature	°C	-11	55.0

Blocking time per day [h/d]	h/d	3
-----------------------------	-----	---

electrical input

rated power of source pump	W	245
rated power of sink pump	W	90
rated power of storage pump for heating buffer	W	0
rated power of storage pump for DHW storage	W	90

Calculation results**System**

Overall Seasonal Performance Factor SPF_{sys}	-	2.95
Seasonal Performance Factor heating $SPF_{sys,h}$	-	3.14
Seasonal Performance Factor domestic hot water $SPF_{sys,DHW}$	-	2.11

electricity consumption

Total electricity consumption	kWh	7871
fraction for back-up heating	%	0.006
fraction for back-up domestic hot water	%	0.0
fraction for auxiliaries	%	14.1
electricity input to cover storage losses		5.8

Storage losses

Storage losses heating buffer		282
share of storage losses heating buffer	%	0.01
Storage losses DHW		927
share of storage losses DHW	%	23.3

Generator

Overall seasonal performance factor SPF_{gen}		3.40
seasonal performance factor heating $SPF_{gen,h}$		3.57
seasonal performance factor DHW $SPF_{gen,DHW}$		2.75

Project name

Novelan_Neubau_Electroboiler.xls

parameter**unit****values****Input data Building**

Generation load at design outdoor temperature	kW	5
heating requirement	kWh/a	10039
Domestic hot water requirement	kWh/a	3053
Share of hot water energy demand	%	23.3
cold water temperature	°C	15
hot water tap temperature	°C	55
hot water temperature generated with the heat pump	°C	55

Meteorological data

meteorological site		Zurich SMA
design outdoor temperature	°C	-11

Parameter heating system**EN 255-2**

		B0/W35	B0/W50
heating capacity	W	9477	9282
Electrical power input	W	2179	3094
COP	-	4.35	3.00

Storage heat loss (U*A)-value) heating	W/K	0.00
--	-----	------

heating curve

		outdoor	supply
supply temperature at upper temperature limit for heating	°C	15	25.2
supply temperature at outdoor design temperature	°C	-11	35.0

Blocking time per day [h/d]	h/d	3
-----------------------------	-----	---

electrical input

rated power of source pump	W	245
rated power of sink pump	W	90
rated power of storage pump for heating buffer	W	0
rated power of storage pump for DHW storage	W	90

Calculation results**System**

Overall Seasonal Performance Factor SPF_{sys}	-	1.97
Seasonal Performance Factor heating $SPF_{sys,h}$	-	3.76
Seasonal Performance Factor domestic hot water $SPF_{sys,DHW}$	-	0.77

electricity consumption

Total electricity consumption	kWh	3596
fraction for back-up heating	%	0.0
fraction for back-up domestic hot water	%	0.0
fraction for auxiliaries	%	18.1
electricity input to cover storage losses	%	23.3

Storage losses

Storage losses heating buffer		0
share of storage losses heating buffer	%	0.0
Storage losses DHW		927
share of storage losses DHW	%	23.3

Generator

Overall seasonal performance factor SPF_{gen}		2.26
seasonal performance factor heating $SPF_{gen,h}$		4.54
seasonal performance factor $SPF_{gen,DHW}$		1.00

KWT_Neubau.xls									
System boundary	performance	thermal	thermal	electricity	electricity	electricity	elektrisch	remarks	
	[-]	[kWh]	[kWh]	[kWh]	[kWh]	[kWh]	[kWh]	system Fig. 2	
Input data									
heating energy requirement				10039					
Domestic hot water energy requirement				3053					
Heating operation									
used energy heating produced with heat pump			10039	1911					
electricity input to cover cyclic losses				12					dynamic heat pump test
produced energy to cover storage losses			0	0					
source pump (external power fraction)				137					1049 Std. à 131 W
SPF_{gen,h,hp}	4.87	10039	10039	2060	2060				
back-up resistance heating				0					
storage loading pump				0					1049 Std. à 0 W
SPF_{sys,RAVEL,h}	4.87			10039	2060				
circulation pump running heat pump (external power)									
circulation pump standing heat pump (rated power)									
SPF_{sys,h}	3.97			10039					
Domestic hot water operation									
used energy DHW			3053	1156					
source pump (fraction used energy DHW)				230					1753 Std. à 131 W
source pump (fraction stand-by)				81					466 Std. à 131 W
produced heat to cover storage losses			602	381					Std. à 62 bis 57 W single
			209	84					Std. à 37 bis 38 W combined
SPF_{gen,DHW}	2.02	3864	3864	1912	1912				
storage loading pump DHW (fraction DHW)									
storage loading pump DHW (fraction stand-by)									pump included in COP EN255-3
SPF_{sys,DHW}	1.60			3053	1912				pump included in COP EN255-3
Overall seasonal performance factor									
SPF_{gen}	3.50	13903		3972					
SPF_{RAVEL}	3.30			13092					
SPF_{sys}	2.95			13092					4442

KWT_Retrofit.xls									
System boundary	performance [-]	Generation (WQA,WP) Fig. 29		RAVEL (WEA) Fig. 31		System Fig. 2		remarks	
		thermal [kWh]	thermal [kWh]	thermal [kWh]	electricity [kWh]	electricity [kWh]	electricity [kWh]		
Input data									
heating energy requirement				20158					
Domestic hot water energy requirement				3053					
Heating operation (EN 255-2)									
used energy heating produced with heat pump			19954	19954	5089				
electricity input to cover cyclic losses					52				dynamic heat pump test
produced heat to cover storage losses heating			282		72				
source pump (external power fraction)					289				2207 hours à 131 W
SPF_{gen,h,hp}	3.68	20236	20236	20236	5501	5501			
back-up resistance heating						204			
storage loading pump (external power fraction)						197			2207 hours à 89 W
SPF_{sys,RAVEL,h}	3.42			20158	5902	5902			
circulation pump running heat pump (rated power)							199		2207 hours à 90 W
circulation pump standing heat pump (rated power)							272		3022 hours à 90 W
SPF_{sys,h}	3.16			20158			6373		
DHW operation (EN 255-3)									
used energy DHW				3053	1091				
source pump (fraction used energy DHW)					195			1490 hours à 131 W	
source pump (fraction stand-by losses DHW storage)					52			396 hours à 131 W	
produced heat to cover storage losses DHW			513		324			5541 hours à 62 to 57 W single	
			298		105			3219 hours à 28 to 35 W combined	
SPF_{gen,DHW}	2.19	3884	3884	3864	1767	1767			
storage loading pump DHW (fraction used energy DHW)									
storage loading pump DHW (fraction stand-by)							0		pump included in COP EN255-3
							0		pump included in COP EN255-3
SPF_{sys,DHW}	1.73			3053	1767	1767			
Overall seasonal performance									
SPF_{gen}	3.32	24100			7268				
SPF_{RAVEL}	3.03			23211	7669				
SPF_{sys}	2.85			23211			8139		

Novelan_Neubau.xls									
System boundary	performance [-]	Generation (WQA,WP) Fig. 29		RAVEL (WEA) Fig. 31		system Fig. 2		remarks	
		thermal [kWh]	thermal [kWh]	thermal [kWh]	electricity [kWh]	electricity [kWh]	electricity [kWh]		
Input data									
heating energy requirement				10039					
Domestic hot water energy requirement				3053					
Heating operation (EN 255-2)									
used energy heating produced with the heat pump				10039	2005				
electricity input to cover cyclic losses					12				dynamic heat pump test
produced heat to cover storage losses heating				0	0				
external power source pump (external fraction)					192				1018 Std. à 189 W
SPF_{gen,h,hp}	4.54	10039	10039	10039	2210	2210			
Back-up resistance heating				0		0			
storage loading pump external						0			1018 Std. à 0 W
SPF_{sys,RAVEL,h}				10039		2210	2210		
circulation pump running heat pump (external power)							80		1018 Std. à 78 W
circulation pump standing heat pump (rated power)							379		4211 Std. à 90 W
SPF_{sys,h}	3.76			10039			2669		
DHW operation (EN 255-3)									
used energy DHW with heat pump									
source pump (fraction used energy DHW)				3053	892				405 Std. à 189 W
source pump (fraction stand-by)					76				123 Std. à 189 W
produced heat to cover storage losses DHW					927				8760 Std. à 54 to 50 W
SPF_{gen,DHW}	2.75	3980	3980		1448	1448			
storage loading pump (fraction for used energy DHW)									pump included in COP 255-3
storage loading pump (fraction for stand-by DHW)							0		pump included in COP 255-3
SPF_{sys,DHW}	2.11			3053		1448	1448		
Overall seasonal performance									
SPF_{gen}	3.83	14019			3657				
SPF_{RAVEL}	3.58			13092		3657			
SPF_{sys}	3.18			13092	0	0	4116		

Novelan_Retrofit.xls									
System boundary	Generation performance [-]	thermal [kWh]	Fig. 29 thermal [kWh]	RAVEL(WEA) thermal [kWh]	Fig. 31 electricity [-]	Fig. 31 electricity [kWh]	system Fig. 2 electricity [kWh]	remarks	
Input data									
heating energy requirement				20158					
Domestic hot water energy requirement				3053					
Heating operation (EN 255-2)									
used energy heating produced with heat pump			20046	20046	5180				
electricity input to cover cyclic losses					53				dynamic heat pump test
produced heat to cover storage losses heating			282		73				
external energy source pump					396				2095 Std. à 189 W
SPF_{gen,hp}	3.57	20327	20327		5701	5701			
Back-up resistance heating				112		112			
storage loading pump (external power fraction)						184			2095 Std. à 79 W
SPF_{sys,RAVEL,h}	3.37			20158		5977	5977		
circulation pump at running heat pump (external power)							164		2095 Std. à 79 W
circulation pump at standing heat pump (rated power)							282		3134 Std. à 90 W
SPF_{sys,h}	3.14			20158			6424		
DHW operation (EN 255-3)									
used energy DHW with heat pump			3053	3053	892				
source pump (fraction used energy DHW)					76				405 Std. à 189 W
source pump (fraction stand-by)					23				123 Std. à 189 W
produced heat to cover storage losses DHW			927		456				8760 Std. à 54 to 50 W
SPF_{gen,DHW}	2.75	3980	3980		1448	1448			
storage loading pump DHW (fraction for used energy DHW)							0		pump included in COP EN 255-3
storage loading pump DHW (fraction for stand-by)							0		pump included in COP EN 255-3
SPF_{sys,DHW}	2.11			3053		1448	1448		
Overall seasonal performance factor									
SPF_{gen}	3.40	24307			7148				
SPF_{RAVEL}	3.13			23211		7425			
SPF_{sys}	2.95			23211			7871		

